

# XRS4

## X-RAY GENERATOR

# OPERATOR'S MANUAL



 **Golden Engineering**  
*Portable X-ray Technology*

Original Instructions February, 2016

<b>CONTENTS</b>	<b>PAGE</b>
1.0 INTRODUCTION.....	3
2.0 WARNINGS.....	3
ELEVATION WARNING.....	3
DUTY CYCLE.....	3
3.0 PHYSICAL DESCRIPTION.....	4
HIGH VOLTAGE PULSER/TUBEHEAD.....	4
BASE.....	4
BATTERY PACK.....	4
BATTERY CHARGER.....	4
CONTROLS.....	5
CABLE CONNECTOR DIAGRAM.....	6
4.0 DESCRIPTION OF OPERATION.....	7
BLOCK DIAGRAM.....	7
5.0 <b>OPERATING INSTRUCTIONS</b> .....	<b>8</b>
OPERATING PRECAUTIONS.....	9
EXCLUSION ZONE.....	9
NAVIGATING THE MENU .....	10
SELECTING PULSES.....	11
TIME DELAY OPTION.....	12
MULTIPLE PULSE TRAIN OPTION.....	13
DUTY CYCLE EXCEEDED.....	14
PULSE COUNTERS.....	14
PULSE SETTINGS.....	15
6.0 MAINTENANCE.....	15
DOSE MEASUREMENT.....	15
TUBE REPLACEMENT.....	15
7.0 TROUBLE-SHOOTING.....	16
8.0 INSTRUCTIONS FOR REPAIR.....	17
FUSE REPLACEMENT.....	17
REMOVING BOARDS.....	17
BOARD INSTALLATION.....	17
SOFTWARE.....	20
STORAGE, TRANSPORT, DISPOSAL.....	20
9.0 WARRANTY.....	20
MANUFACTURER & EUROPEAN REPRESENTATIVE.....	20
<b>RETURNING REPAIR INSTRUCTIONS</b> .....	<b>20</b>
10.0 SPECIFICATIONS.....	21
PHYSICAL DIMENSIONS.....	21
X-RAY OUTPUT.....	21
ELECTRICAL & THERMAL CHARACTERISTICS.....	21
12.0 SPARE PARTS.....	21

## 1.0 INTRODUCTION

**The XRS4 produces high levels of radiation and must be operated by qualified personnel who have read the Warning and Operations section of the manual before operating the device.**

The XRS4 is an industrial type open beam x-ray generator intended to radiograph inanimate objects. The XRS4 is a pulsed x-ray device that produces x-ray pulses of very short duration (10 nanoseconds). The energy produced by the XRS4 is up to 370kVp, which makes it possible to radiograph up to one (1.5) inch (3.81 cm) of steel.

XRS4 standard accessories are two keys, two battery packs, and one battery charger. Remote cable, carrying case, and film developing equipment are also common accessories.

## 2.0 WARNINGS

The XRS4 is a pulsed X-ray generator that emits hazardous ionizing radiation when pulsing. The XRS4 should only be **operated** by **authorized personnel** who are properly trained to safely operate the generator. The XRS4 must be **registered** with proper authorities prior to use and should **not** be used to intentionally expose humans.

Develop and closely follow a safe operating system for using the XRS4. The safe operating system must ensure that no one is exposed to radiation above the permissible limits which are 2 mR (0.02 mSv) per hour for a member of the public. ***The safe operating system must ensure the XRS4 is used within federal and state guidelines.***

All operators and users of the XRS4 x-ray machine must wear a personal radiation monitoring device, such as a TLD (thermo luminescent dosimeter), film badge, and/or a pocket dosimeter **consistent with the appropriate federal, territorial or provincial standards** (note: an electronic dosimeter will not detect the XRS4 radiation pulses). If an operator or bystander is exposed to an unacceptable level of radiation contact your Radiation Safety Officer and/or appropriate health care provider.

Due to the short pulse width of the XRS4, survey meters of the Geiger-Mueller and scintillator type do not accurately detect the radiation emitted from the x-ray source.

***Survey meters should be of the ionization type and should be used in the integration mode.*** Survey meters must not be used in the rate mode because the XRS4 does not produce constant radiation. The XRS4 produces very high rates of radiation for very short periods of time resulting in either unrealistically high readings or no readings for a survey meter in rate mode.

**The XRS4 has no explosion proof rating and should not be used in an explosive atmosphere. The Spark Gap is vented to the air and could be a source of ignition. THE STANDARD XRS4 WITHOUT A MODIFIED SPARK GAP WILL LIKELY FAIL PREMATURELY WHEN USED ABOVE 5000 ft. (1524 m) ELEVATION.**

**DUTY CYCLE WARNING.** *The XRS4 is a light duty machine that is not made to pulse continuously.* The maximum duty cycle for the XRS4 is 200 pulses every four minutes (3000 pulses per hour). Additional 30 second rest every 50 pulses is suggested for applications requiring more than one hour continual use or in temperatures exceeding 90 degrees F. Exceeding the duty cycle will shorten the life of the tube and head.

### 3.0 PHYSICAL DESCRIPTION

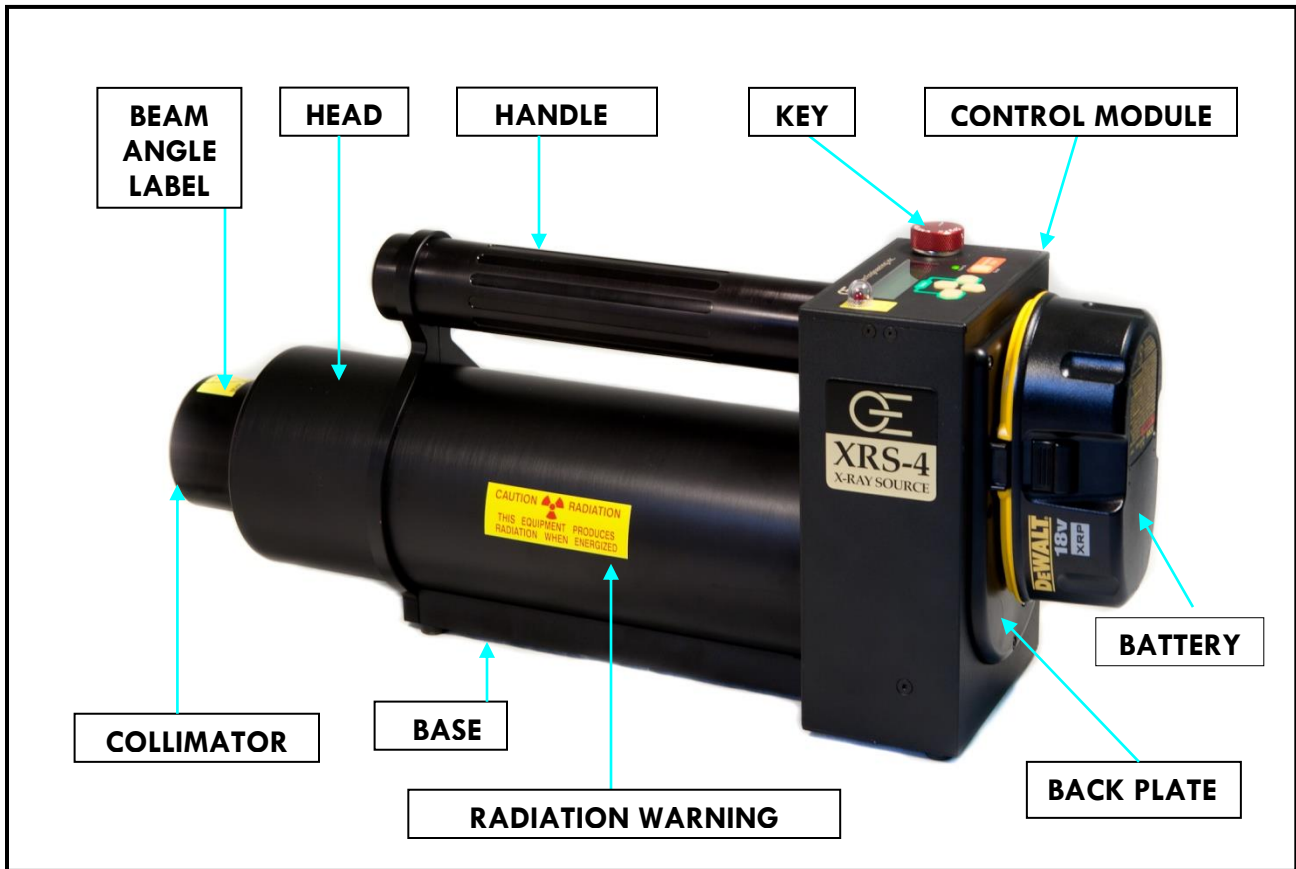

**HIGH VOLTAGE PULSER/TUBEHEAD.** The main body of the XRS4 is the tube head which contains the tube cavity, cold cathode type X-ray tube, spark gap, high voltage capacitor, and transformer. The standard collimator located on the front of the head limits the X-ray beam to 40 degrees. Special order collimators up to 85 degrees are available.

**BASE.** The base of the XRS4 contains the identification label and a threaded 1/4-20 insert that can be attached to any standard camera tripod. Identification label indicates the model, manufacturer, and serial number is located on the bottom of the XRS4 base.

**BATTERY PACK.** The standard battery pack is a DeWalt® 18V nickel-cadmium battery. Optional battery chemistry or voltage may be available.

**BATTERY CHARGER:** The standard battery charger is the DeWalt® DW9116 110V charger or DE9108 220V charger. Battery charge time is one hour. See battery charger manual for additional instructions and warnings.

## CONTROLS



### RED X-RAY PULSING LIGHT:

- Blinks after time delay button or remote cable button is pressed **AND** between multiple pulse trains.
- Stays on continuously while the XRS4 pulses.
- Blinks at a slower rate between multiple pulse trains.
- This is a failsafe warning light. **If the light does not work the X-ray unit will not pulse.**

**LIQUID CRYSTAL DISPLAY (LCD):** 32 character LCD. Home screen displays **Pulse count (PC)**, **Multiple pulse trains (\*)**, **Time Delay (DEL)**, and **Ready to Fire**. See instructions for menu options.

**DELAY SWITCH:** Initiates time delay mode count down when left and right arrows pressed simultaneously.

**POWER ON LIGHT:** Illuminates when battery voltage is applied to control module.

**ENTER/ EMERGENCY STOP SWITCH:** ENTER used when menu options are selected.

**EMERGENCY STOP** stops the unit during delay count down mode or between multiple pulse trains.

**DIRECTIONAL ARROWS:** Left, Right, Up, Down used to navigate through LCD and menu options.



# XRS4 REAR VIEW/CABLE CONNECTOR

PIN #	DESCRIPTION
1	+5 VOLTS 100 ma MAXIMUM
2	REMOTE SWITCH
3	REMOTE SWITCH – NO DELAY
4	X-RAY ON SIGNAL
5	COMMON 0 VOLTS

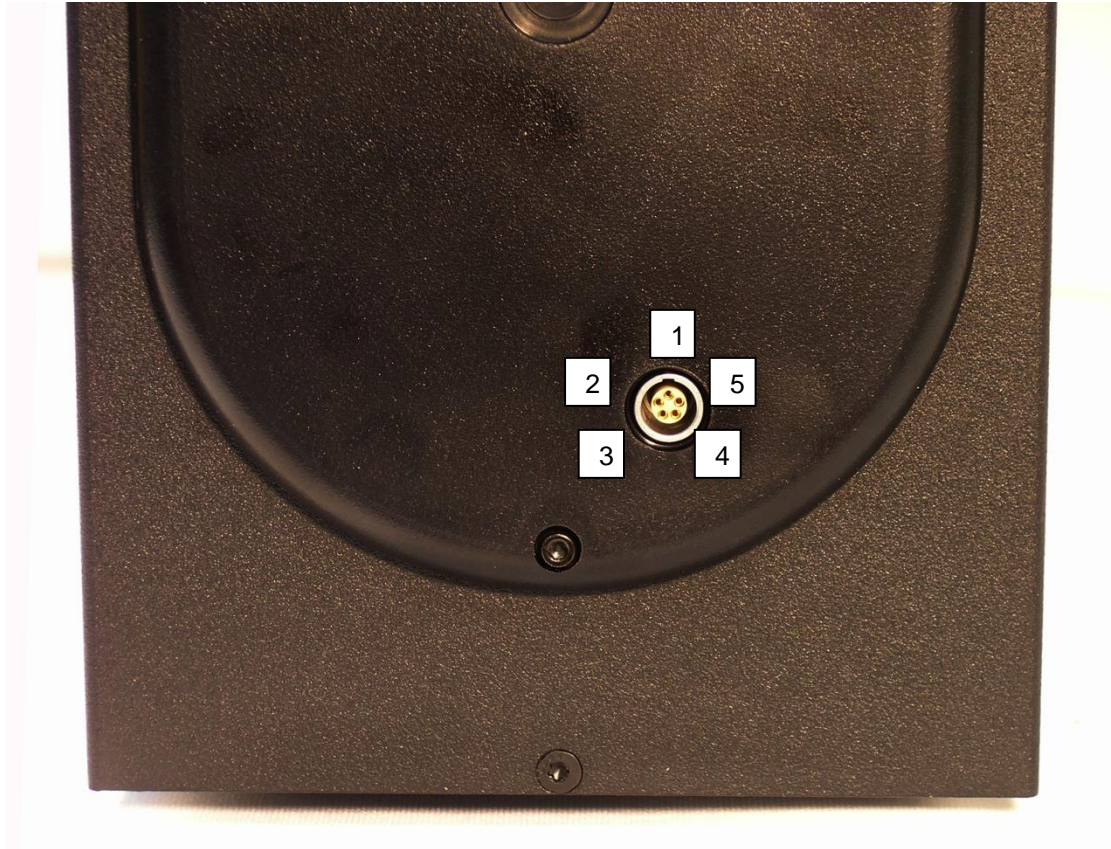

REMOTE CONNECTOR: LEMO EPG.0B.305.HLN  
MATING CABLE PLUG: LEMO FGG.0B.305.CLAD 56Z

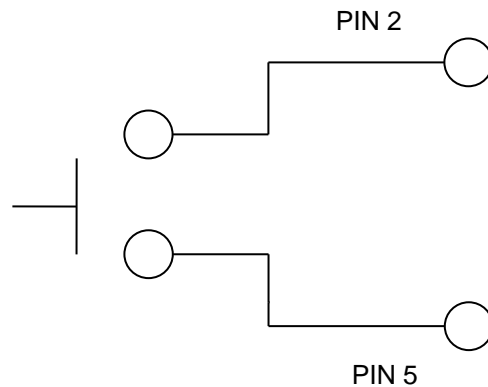

Remote switch inputs are activated when grounded.

## 4.0 DESCRIPTION OF OPERATION

The block diagram below illustrates how the XRS4 functions. The following sequence of events takes place each time the XRS4 is fired:

1. User initiates operation of the machine.
2. The control section sends a signal to the converter section to begin oscillating.
3. Once oscillating, the converter section changes the 18 volts DC to 22Khz AC.
4. The transformer charges the High Voltage Capacitor to about 10,000 volts.
5. The spark gap arcs after the High Voltage Capacitor reaches proper voltage.
6. The pulse detector signals the control block that the unit has pulsed.
7. As the High Voltage Switch is closed, a high voltage transient of approximately 370,000 volts and 10 nanoseconds in duration is applied across the x-ray tube generating x-rays.

The closing of the High Voltage Switch produces an audible pulsing sound. **The XRS4 cannot produce x-rays without the pulsing sound so it serves as an additional warning the XRS4 is functioning.**

This unit generates x-rays through high voltage bombardment of a tungsten target. **The XRS4 does not contain radioactive materials.** All the high voltage is contained within the aluminum canister and as long as the canister is not punctured the operator is not exposed to dangerous voltages.

### BLOCK DIAGRAM

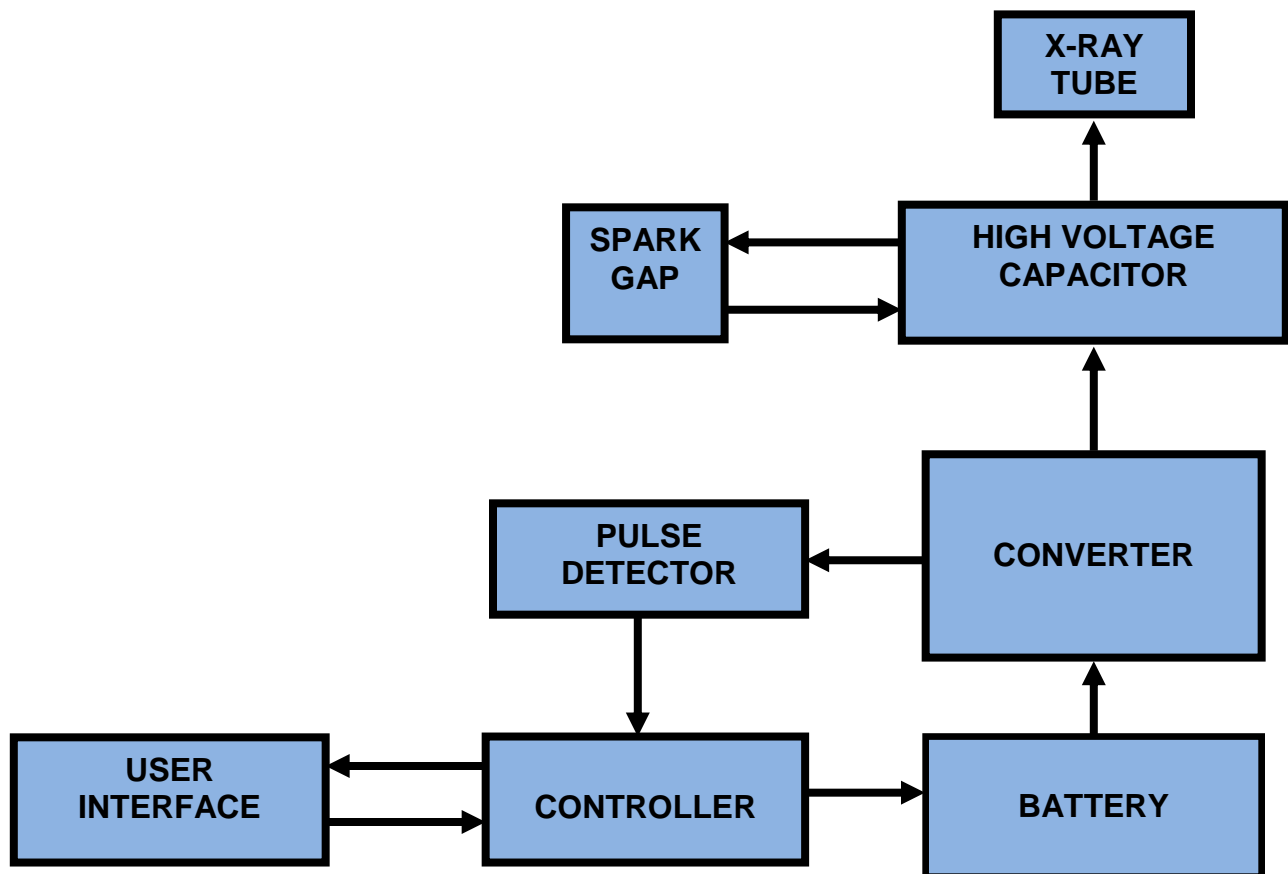

## 5.0 OPERATING INSTRUCTIONS

The following are basic operation instructions to take an X-ray image using the XRS4. Certain applications may require modifications to these basic procedures.

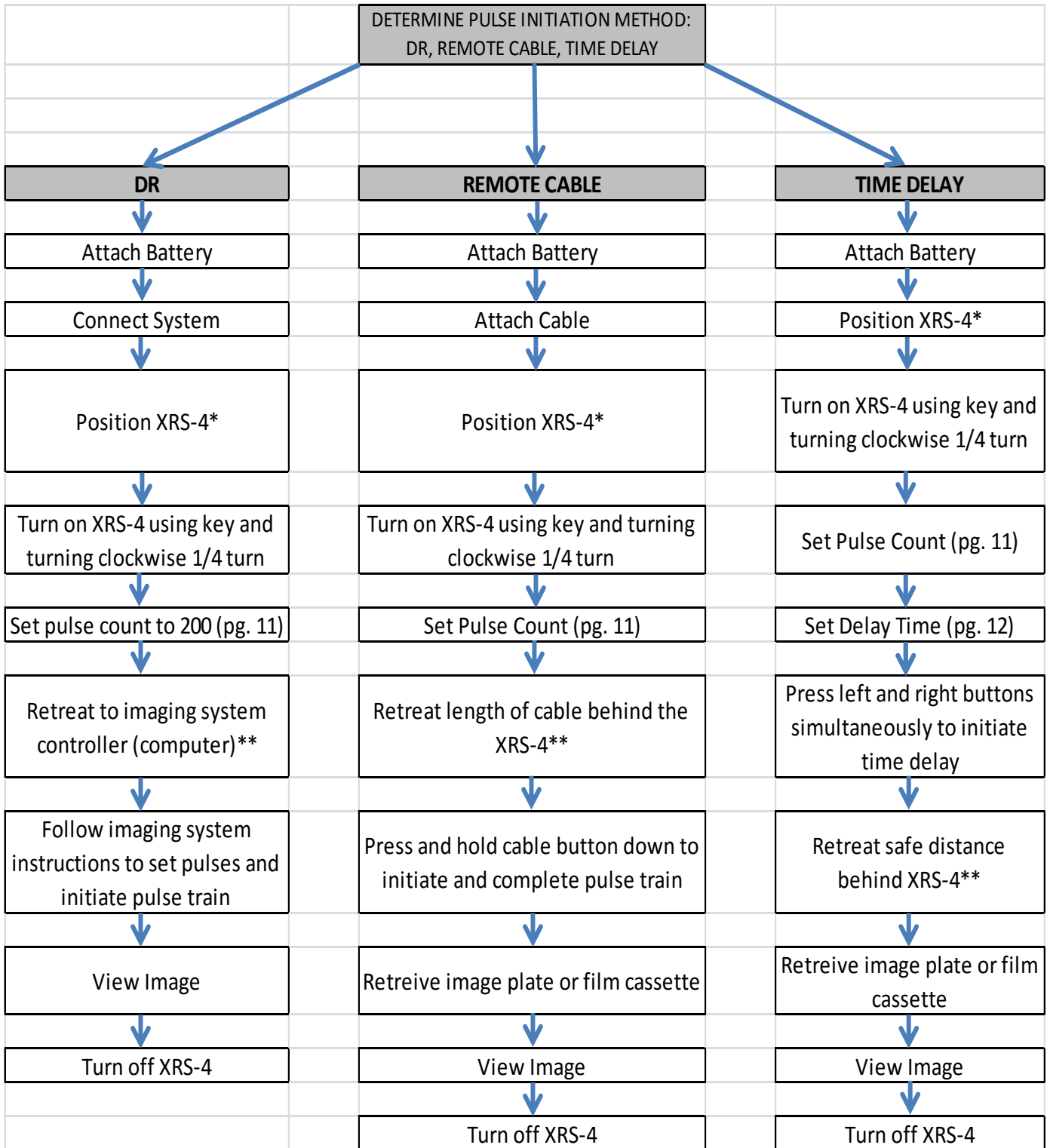



\*XRS-4 should be positioned directly in front of the object to be X-rayed and the imager placed directly behind the object to be X-rayed. Imager should be placed as close to the object as possible. Distance between XRS-4 and imager is usually 24 to 72 inches (30 to 180 cm). XRS-4 should be stabilized during use on a flat surface, a tripod, or a custom fixture suitable for holding the 22 pound (9 Kg) XRS-4.

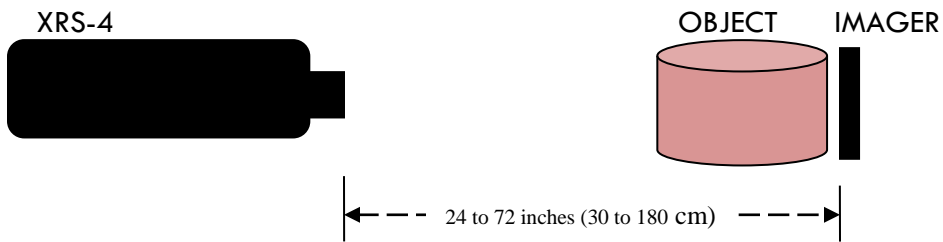

**\*\*OPERATING PRECAUTIONS:** The operator should always stand at least 20 feet (6m) behind the X-ray unit and clear all personnel at least 20 feet (6m) behind the unit or at least 100 feet (30m) from the front of the unit before pulsing. The exclusion zone (below) should be a controlled area free of all personnel while X-ray pulses.

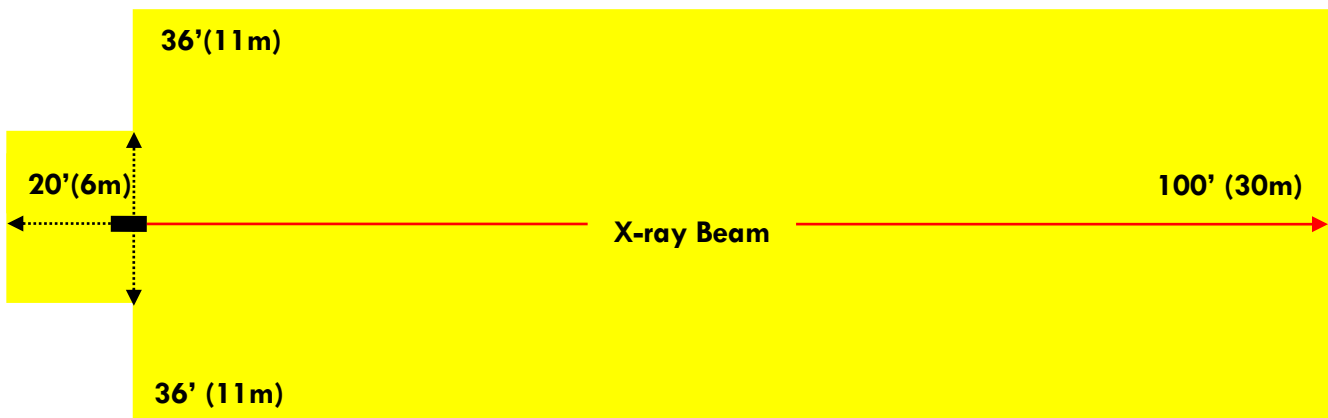

Figure 4: Exclusion Zone

## NAVIGATING THE MENU



Home



Press Right Arrow to advance to next menu



Press Left Arrow to go back to home



Press enter to view settings menu options



Down Arrow to scroll to next menu option



Press enter to select option >



## SET PULSE COUNT



Press Right Arrow button from home screen



Press Enter button from Settings screen



Select **Set Pulse Count** and press Enter Button

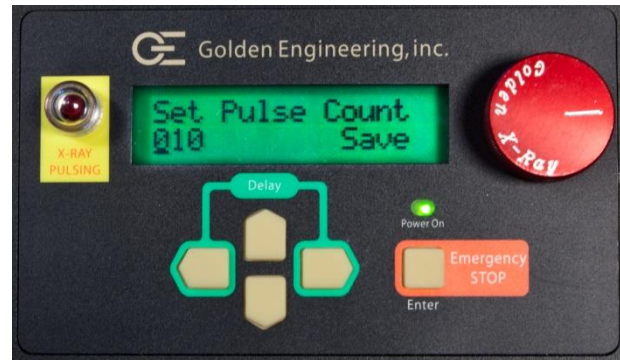

Use LEFT / RIGHT arrow to select Digit  
Use UP / DOWN arrows to change number  
Pulse setting from 001 to 999\*



Press Right Arrow to **Save** and Press enter



Home screen appears after pulse count is saved

\*Any pulse setting above 200 will automatically default to multiple pulse trains of 50 with 45 second delay between each pulse train.



**SET DELAY TIME (Before first pulse)**



Press Right Arrow button from home screen



Press enter button from **Settings** screen



Select **Set Delay Time** press Enter button



Use Left/Right arrows to select digit  
Use UP/DOWN arrows to change number  
Delay option from 5 to 240 seconds



Press Right Arrow to **Save** and press Enter



Home Screen appears when Time delay is saved

- Time delay is the delay time before the first pulse **only** when firing the unit directly from the XRS4 control panel by depressing left and right arrow buttons simultaneously.
- Time delay does not affect delay time between multiple pulse trains and does not affect delay time before the first pulse when using a remote cable or when X-ray is fired from a digital imaging system controller.

## MULTIPLE PULSE TRAINS

Option is used to enter multiple pulse trains and rest period between each pulse train.



Select **Multiple Trains** press Enter



Select pulse trains 1 to 999



Select seconds between pulse trains and save



Must select Y to continue



Home screen Appears with \* to designate multiple pulse trains.

- If multiple pulse trains are entered **Multi-Trains set Continue** screen appears when unit is powered up.
- Operator must select Y and press enter to continue with multiple pulse trains.
- If operator does not select Y and press enter the unit will default to a single pulse train. This safety feature ensures operator's knowledge that multiple pulse trains are set.
- Red X-ray pulse light blinks between multiple pulse trains.

Multiple pulse train option can be used slow the pulse rate to one pulse per second by entering a pulse count of one, enter desired number of pulse trains (pulses), and select one second between pulse trains.



## DUTY CYCLE



If operator selects multiple pulse trains that exceed the duty cycle of 200 pulses in 4 minutes the LCD will display: **Setting exceed duty cycle** for four seconds followed by **Continue? Yes/No** screen. If the operator selects **No** the Unit will default to a single pulse train. If the operator selects Yes on the continue screen the LCD will display a second warning **May void Warnty Continue?** If operator selects Y the pulse count will remain with the multiple pulse trains in place. When the unit is returned for repair **Golden Engineering can see how many times the duty cycle had been exceeded.** If the repairs required to the machine are caused by excessive use the warranty may be voided.

## PULSE COUNTERS

XRS4 contains two pulse counter options. The first pulse counter can be reset to zero by selecting **Pulse Counter** then pressing the UP ARROW to reset. This feature allows the operator to track the number of pulses fired from a desired event like the last tube change or total number of pulses for a specific job. The **Lifetime Pulse** option displays the total number of pulses on the machine and cannot be reset. Unlike previous versions there is no multiplier – the number displayed on the LCD is the exact number of pulses on the machine.





### SUGGESTED PULSE SETTINGS

The chart below lists **approximate** pulses necessary to penetrate various materials. Settings vary greatly depending on imaging system used. Refer to imaging system instructions for more information.

MATERIAL	PULSE SETTING 24 inches between x-ray & imager
CARDBOARD / LIGHT WOOD / PLASTIC	2
LIGHT METAL	5-10
STEEL 1/4"	25
STEEL 1"	50
STEEL 1.5"	99
BRASS 1/8" to 1/4"	50- 99

The following is true when using film or digital systems that generate a positive image. If the radiograph is too dark, the film is underexposed. If the radiograph is too light the film is overexposed. **Underexposure** can be corrected by increasing the number of pulses and/or decreasing the distance between the imaging medium and the XRS4. **Overexposure** can be corrected by reducing the number of pulses and/or increasing the distance between the imaging medium and XRS4.

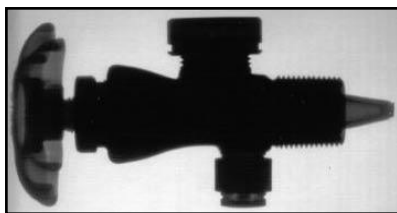

Underexposed



Overexposed



Correct exposure (pulse setting)

## 6.0 MAINTENANCE

**X-RAY DOSE MEASUREMENT** Using a dosimeter, the average X-ray dose for new tube can be established.

- With the dosimeter located 1 foot from the front of the case and in line with the center of the beam angle label, the reading for 10 pulses should be 40 mR to 70 mR.
- The leakage sheet illustrates the X-ray dose and maximum allowable radiation leakage levels for each X-ray unit. A completed copy of this form accompanies each X-ray.

**TUBE REPLACEMENT** If you have a tube replacement kit refer to instructional disk included with the kit. If you do not have a kit the unit must be sent back to Golden Engineering or an Authorized Distributor for tube replacement. Tube life is 50,000 to 100,000 pulses. Under normal conditions the tube's output will decrease slowly with use. If the tube is broken or the glass cracks the tube output will cease immediately.

## 7.0 TROUBLESHOOTING

SYMPTOM	TEST	ACTION
No "power on" light	-Check battery voltage -Check battery connection	- Replace or charge battery - Make sure battery is securely attached and battery clips are not bent or broken.
Power on lights, but X-ray does not pulse.	-Check the battery voltage. -Check the 2amp fuse.	-Charge or replace the battery. -Replace the fuse if necessary.
Power on lights, X-ray pulsing light does not illuminate, X-ray dose not pulse		- Replace the X-ray pulsing light
<b>Low Battery Please Charge</b>	-Appears if battery is below 17V	-Charge the battery
X-ray pulses, but no image or black image.	-Test X-ray output.	-Replace the tube.
Unit stops pulsing in the middle of a pulse train and LCD displays 00.	-Check the battery voltage. -Check 20 amp fuse.	- Charge battery if necessary. - Replace the fuse if blown.
Unit makes loud popping noise while pulsing.		- <b>Stop immediately and return for repair.</b>
Oil leaking from unit.		Return for repair.



## 8.0 INSTRUCTIONS FOR REPAIR

**FUSE REPLACEMENT** Requires T-10 Torx driver & needle nose pliers.

1. Remove the back plate. Remove the 5 screws in the back plate then pull the back plate off slowly maneuvering the battery terminal connecting wires through the opening in the oscillator board.
2. The 20 amp fuse is the white one inch long fuse on the left side of the oscillator board. The 15 amp fuse is a small green fuse in the center of the oscillator board. The 15 amp fuse is soldered in place and can only be replaced using a soldering iron.

**REMOVING THE BOARDS** Refer to the diagram on page 17

1. Using T10 Torx Remove the 2 screws on both sides of the housing.
2. Using T10 Torx Remove the 5 screws holding the back plate in place.
3. Lift the top plate from the control module.
4. Disconnect the Key Switch wires from the Oscillator Board.
5. Use flat head driver to remove screws holding the Counter Board in place and remove the Counter Board.
6. There are three terminals on the lower left side of the Oscillator Board and one on the lower right. Disconnect the two blue wires, one red wire, and one green signal wire using Philips driver.
7. There are three socket head cap screws holding the oscillator board in place. Two are in the middle of the board and one is at the bottom. Remove these three screws then remove the Oscillator Board.

### BOARD INSTALLATION

1. Install the Oscillator Board.
2. Put the three cap screws through the oscillator board and then put the 1/2" offsets on the back of the screws.
3. Attached the two blue feedback wires, one red feedback wire, and green signal line.
4. Attach the Counter Board to the top plate.
5. Attached key switch wires to the Oscillator board.
6. Set top plate back in place making sure Counter Board and Oscillator Board connect.
7. Reinstall the back plate.
8. Insert and tight the two screws on each side of the control module.

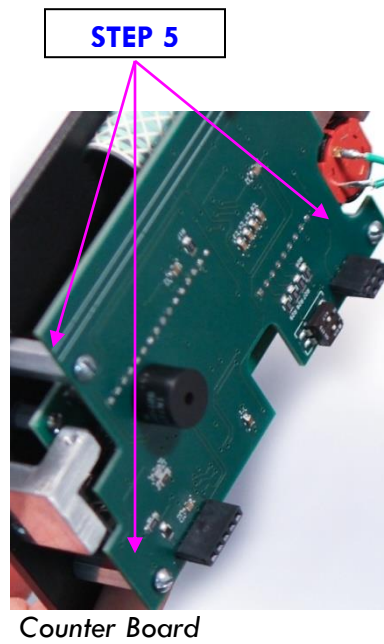
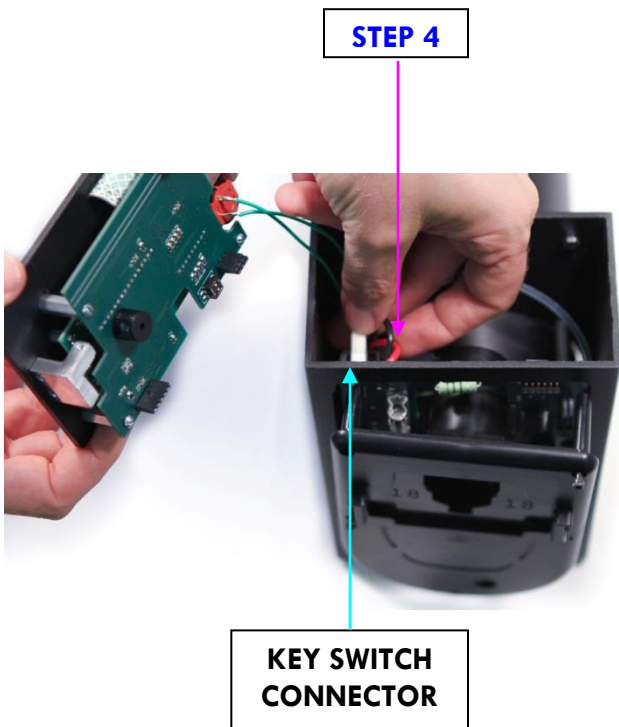
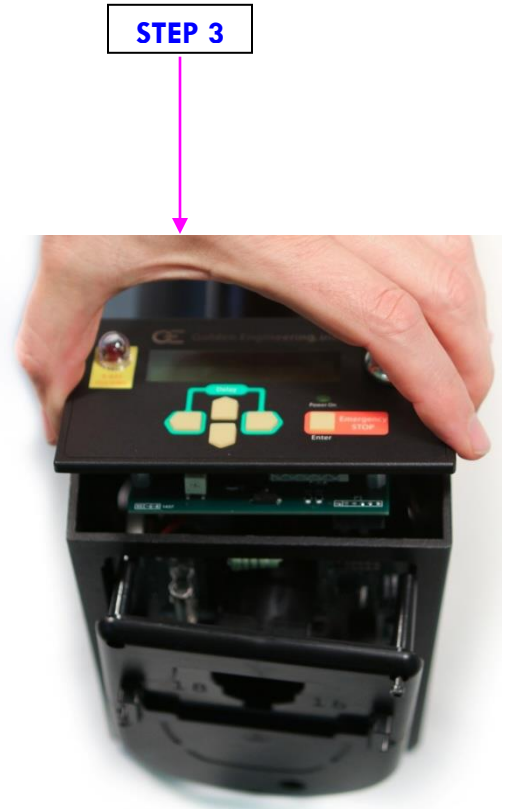
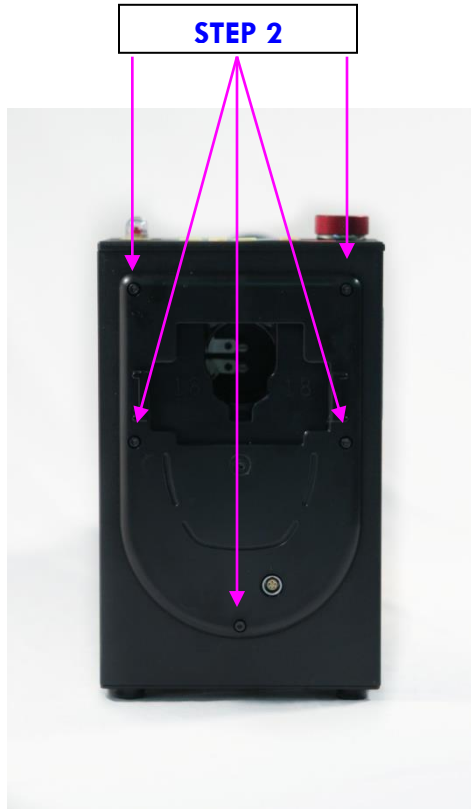

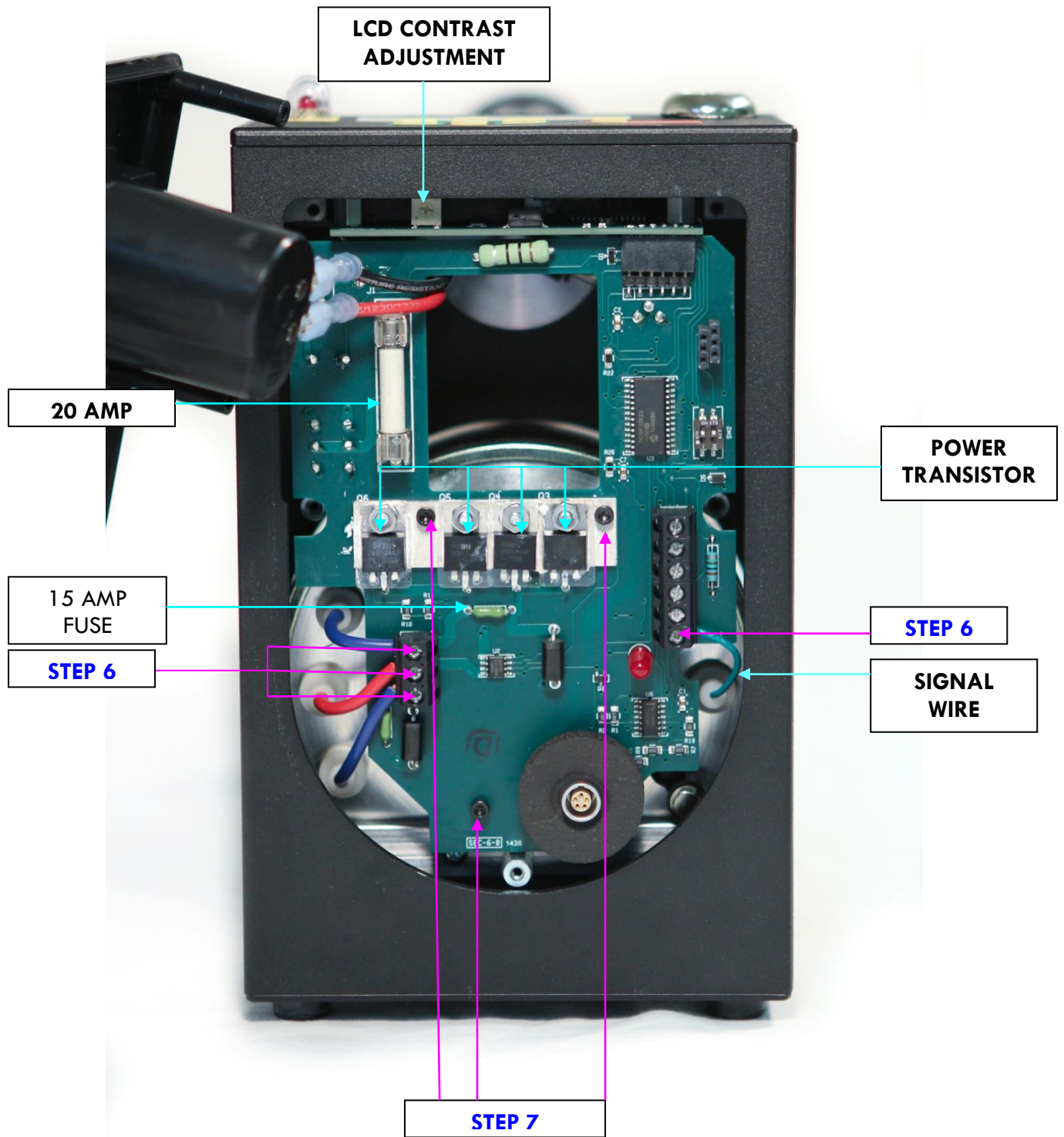

Oscillator Board

## SOFTWARE

The software program that controls the counter board and oscillator board can be identified by turning the key switch on while holding down the Enter Button. Current version of the counter board is 1.7. Current version of the Oscillator board is 1.4.

## INSTRUCTIONS TRANSPORTATION, STORAGE, AND DISPOSAL

The XRS4 is shipped in a rigid case or strong fiberboard box with custom foam insert. When transporting remove the battery pack and transport in a rigid case or fiberboard box with sufficient cushioning. Store the XRS4 in a dry environment within temperature ranges mentioned in the specifications. For disposal remove the tube and follow all applicable environmental laws. Alternatively, the XRS4 may be returned to Golden Engineering for proper disposal.

## 9.0 WARRANTY

Golden Engineering, Inc. warrants XRS4 X-ray unit made and sold by it or its authorized representatives to be free of **defects in materials and workmanship** for a period of twelve (12) months from the date of shipment to the end user. **Warranty does not cover maintenance required due to life.** To make a claim under this limited warranty, customer must ship the entire unit (or the component believed to be defective) to Golden Engineering, post-paid. Golden Engineering, Inc. assumes no liability for units or components shipped until they are actually in the custody of Golden Engineering, Inc. Provided Golden Engineering, Inc. in its sole discretion, is satisfied that the failure is not the result of excessive use, abuse, misuse, accident, modification or improper disassembly or repair, Golden Engineering will provide parts and labor required to repair the unit. Golden Engineering reserves the right to use reconditioned and remanufactured components that meet original specifications. The unit or component will be return shipped to customer at customer's expense. THIS EXPRESS LIMITED WARRANTY IS IN LIEU OF ALL OTHER WARRANTIES AND GUARANTEES, EITHER EXPRESS OR IMPLIED OR CREATED BY OPERATION OF LAW.

<b>XRS4 Manufacturer</b>	<b>European Representative</b>
Golden Engineering, Inc.	Certification Experts Europe
PO Box 185	Nieuwstad 100
Centerville, IN 47330 USA	1381 CE Weesp
Phone: 1-765-855-3493	The Netherlands
Fax: 1-765-855-3492	
Web: <a href="http://www.goldenengineering.com">www.goldenengineering.com</a>	

## RETURNING UNIT FOR REPAIR

- **Complete the repair form** at [www.goldenengineering.com/technical.html](http://www.goldenengineering.com/technical.html) and include a copy of the printed form with the repair. If you do not have internet access prior to sending repair then include a letter containing a brief description of the problem, contact name, phone number, and return address.
- Remove battery before shipping the unit.
- Accessories are not necessary with units shipped back for repair.
- Be sure the unit is securely packaged for shipment and wrap in plastic bag if there is an oil leak.
- Ship to address:  
**Golden Engineering**  
**6364 Means Road,**  
**Centerville, IN 47330 USA**  
**Phone: 1-765-855-3493**  
**EMAIL: [service@goldenengineering.com](mailto:service@goldenengineering.com)**



Serial Number: \_\_\_\_\_

Delivery Date: \_\_\_\_\_

## 10.0 SPECIFICATIONS

<b>PHYSICAL DIMENSIONS</b>	
LENGTH	17.43 inches (44.27 cm)
WIDTH	5.43 inches (13.79 cm)
HEIGHT	7.91 inches (20.09 cm)
WEIGHT	22 pounds (10.5 Kg) with battery
<b>X-RAY OUTPUT</b>	
X-ray dose per pulse	4.5 mR to 7 mR/pulse measured (12 inches in front of unit)
Pulses per battery charge	3000
Pulses per second	9 (Nominal)
Expected tube life (glass tube)	50,000 pulses
X-ray source size	1/8 in. (3mm)
Maximum Photon Energy	370 KVP
X-ray pulse width	10 nanoseconds
<b>ELECTRICAL AND THERMAL CHARACTERISTICS</b>	
Battery voltage	18 volts
Battery type	Nickel Cadmium sub C cells
Battery recharge time	One Hour
Current draw	13 amps @ 18 volts
Current flow	0.25 mA
Temperature range	-10 to 120 degrees F (-23 to 50 degrees C)
Airborne Noise Emissions	80 dB at 10 cm
Maximum duty cycle	200 pulses every 4 minutes (3000 pulses per hour)
High temperature / High use duty cycle	<b>Above 90 Degrees OR continual use, rest 30 seconds every 50 pulses and 4 minutes every 200 pulses</b>
Warm-up	None required

## 11.0 SPARE PARTS AND ACCESSORIES FOR THE XRS4

<b>ITEM</b>	<b>PART NUMBER</b>
Thumbwheel Key	5951020
Flat key	5951040
DeWalt® Battery 18v PLUS DW9096	1800103
DeWalt® Battery Charger (110V) DW9116	1800156
DeWalt® Battery Charger (220V) DE9108	1800157
Remote Cable	1809013
Carrying case (holds X-ray, 2 batteries, charger, cable)	1701680