

XR150

12V X-RAY GENERATOR

OPERATOR'S MANUAL



SEPTEMBER 2021

 **Golden Engineering**
Portable X-ray Technology

INTRODUCTION	3
WARNINGS	4
PHYSICAL DESCRIPTION	5
CONTROL MODULE	7
REAR VIEW	8
REMOTE CABLE CONNECTOR	9
DESCRIPTION OF OPERATION	10
OPERATING INSTRUCTIONS	11
NAVIGATING THE MENU	13
BOOT SCREEN	13
SET NUMBER OF COUNTS/PULSES	14
SET DELAY TIME	14
MANUALLY ENTERING PULSE TRAINS	14
RESET PULSE COUNTER	15
PULSE COUNT EXCEEDS DUTY CYCLE	16
LIFETIME PULSE COUNT	16
BACKLIGHT	17
PULSES PER COUNT	17
DISABLE DUTY CYCLE WARNING	17
GENERATOR IDENTIFICATION	17
MULTIPLE PULSE TRAIN EXCEEDS DUTY CYCLE	18
ERROR MESSAGES	19
TROUBLESHOOTING	20
RECOMMENDED PULSE SETTINGS	21
CE CERTIFICATE	22
SPECIFICATIONS	23
SPARE PARTS AND ACCESSORIES	24
WARRANTY	26
RETURNING UNIT FOR REPAIR	26

INTRODUCTION



RADIATION WARNING

*The X-ray generator produces high levels of radiation and must be operated by qualified personnel who have read the **WARNINGS** and **OPERATING INSTRUCTIONS** sections of the manual before operating the device.*

X-ray generators from Golden Engineering are industrial type open beam X-ray generators intended to radiograph inanimate objects. The devices are a pulsed X-ray device that produces X-ray pulses of very short duration (10-50 nanoseconds). The energy produced by the X-ray generator varies from model to model, and in the XR150 12V is approximately 150 kVp, which makes it possible to radiograph up to one (1/2) inch (1.27 cm) of steel.

Each unit ships with two keys, two 12V battery packs, and one battery charger.

Many users choose to add other accessories like a Remote Cable or Carrying Case. Refer to the Spare Parts and Accessories section for more details.

WARNINGS

The X-ray generators from Golden Engineering are pulsed X-ray generators that emit hazardous ionizing radiation when pulsing. The unit should only be operated by **authorized personnel** who are properly trained to safely operate the X-ray generator. The X-ray generator must be **registered** with proper authorities prior to use and should not be used to intentionally expose humans.

Develop and closely follow a safe operating system for using the X-ray generator. The safe operating system must ensure that no one is exposed to radiation above the permissible limits which are 2 mR (0.02 mSv) per hour for a member of the public. The safe operating system must ensure the X-ray generator is used within federal and state guidelines.



All operators and users of the X-ray generator must wear a personal radiation monitoring device, such as a TLD (thermoluminescent dosimeter), film badge, and/or a pocket dosimeter consistent with the appropriate federal, territorial or provincial standards. If an operator or bystander is exposed to an unacceptable level of radiation contact your Radiation Safety Officer and/or appropriate health care provider.

NOTE: Electronic dosimeters and survey meters of the Geiger-Mueller and scintillator types may not detect the X-ray Generator's radiation pulses.

Due to the short pulse width of the pulsed X-ray, survey meters of the Geiger-Mueller and scintillator type do not accurately detect the radiation emitted from pulsed X-ray generators.

Survey meters should be of the ionization chamber (ion chamber) type and should be used in the integration mode. Survey meters must **not** be used in the rate mode because the pulsed X-ray generator does not produce constant radiation. Pulsed X-ray generators produce very high rates of radiation for very short periods of time resulting in either unrealistically high readings or no readings for a survey meter in rate mode.

The X-ray generators have **no** explosion proof rating and should **not** be used in an explosive atmosphere. The Spark Gap could be a source of ignition.

PHYSICAL DESCRIPTION

PICATINNY RAIL

The X-ray generator is equipped a 21 mm picatinny rail located on each side of the housing.

CONTROL MODULE



XR150 12V

BATTERY

BATTERY PACK. The standard battery pack is a DeWalt® 12V 3 amp-hour Li Ion battery.

RADIATION WARNING LABEL

HANDLE

The handle of the XR150 is attached to the front sides of the Control Module. Loops are

**BEAM
ANGLE
LABEL**

COLLIMATOR

The standard collimator located on the front of the head limits the X-ray beam to 40 degrees.

TRIPOD MOUNT

HIGH VOLTAGE PULSER/TUBEHEAD

The main body of the X-ray Generator is the tube head. The head contains the tube cavity, cold cathode type X-ray tube, spark gap, high voltage capacitor, and transformer.

BASE

The base of the unit contains an identification label and a 1/4-20 brass insert compatible with standard camera tripods. The base also accommodates a quick release external tripod mount. The identification label located on the bottom of the generator lists the manufacturer's name, model number, serial number, weight, volt, amp, and production date.



CONTROL MODULE

BEAM ANGLE LABEL



LIQUID CRYSTAL DISPLAY (LCD)

The 80 character LCD is the main interface with the unit. See the Operating Instructions for more details on the various control screens.

X-RAY PULSING LIGHTS

Blinks once per second after time delay button or remote cable button is pressed to warn that the X-ray Generator is going to pulse. The light stays on continuously while the unit is pulsing.

This is a failsafe warning light. If the light does not work the X-ray unit will not pulse. See settings menu for fail-safe override in emergency situations.

POWER ON LIGHT

Illuminates when battery voltage is applied to control module.

DELAY SWITCH

Pressing both Left and Right arrow buttons simultaneously initiates the delay mode, allowing the operator to use the unit without the remote cable.

ENTER / EMERGENCY STOP

Stops the unit before it begins pulsing or stops the unit in the middle of a pulse train. Also used as the enter button to select desired option.

DIRECTIONAL BUTTONS

Left, Right, Up and Down buttons used to navigate through the menu.

KEY

Main power switch to turn the unit on and off.

MODEL IDENTIFICATION

*Top View
Control Module*



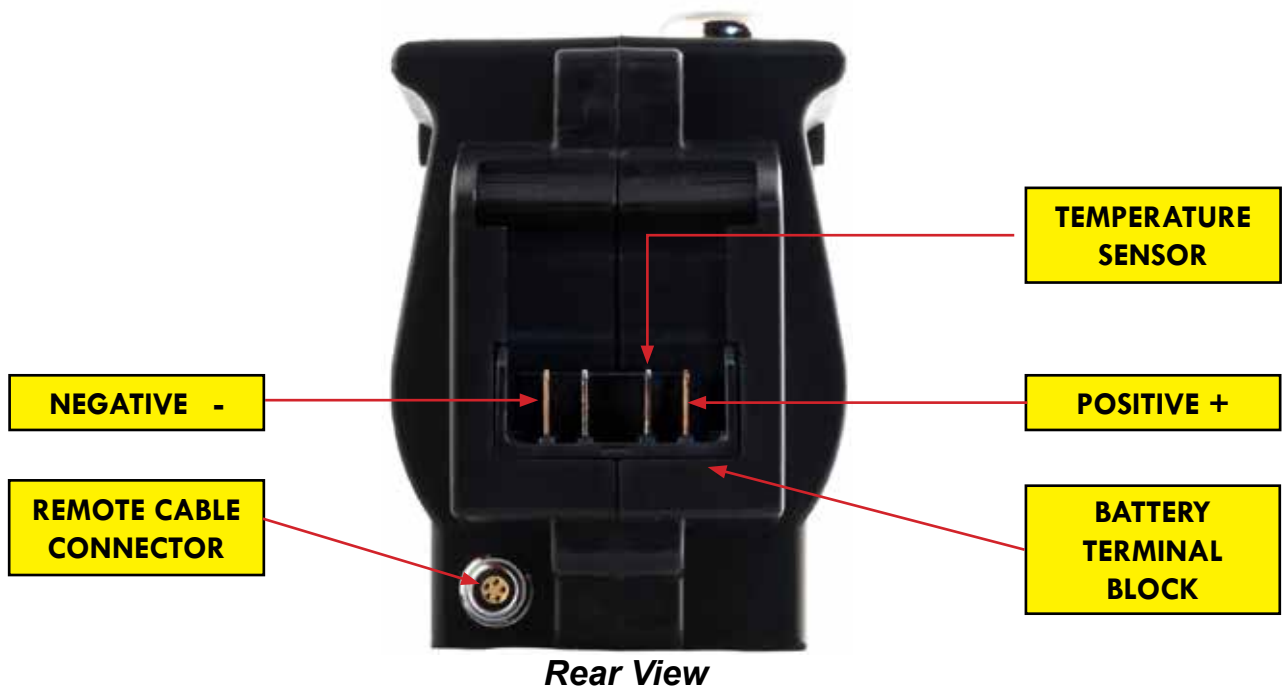

Rear View

BATTERY PACK

The standard battery pack is a DeWalt® 12V 3 amp-hour Li Ion battery. In the USA the battery is rated at 12V, but outside the USA it may be rated as 10.7 or 12V.



BATTERY CHARGER

The standard battery charger is the DeWalt® DCB115 charger for both 110V and 220V. (Note: DeWalt model numbers may change). Battery charge time is typically less than one hour. See battery charger manual for additional instructions and warnings.

REMOTE CABLE CONNECTOR

The X-ray Generator is equipped with Lemo “K” series connector located on the lower left corner of the back of the control module. This is where the remote cable or imaging system cable is attached. Depending on the options of the unit, this may either be 5 pin or 7 pin connector.

See the diagrams and table below for the details of each configuration.

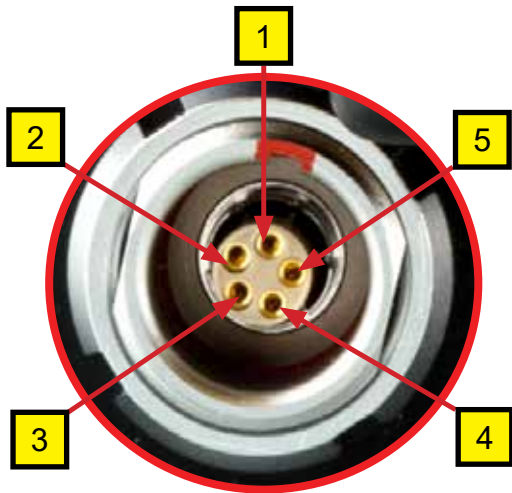

5 PIN K REMOTE CABLE CONNECTOR

REMOTE CONNECTOR: LEMO EEG.0K.305.CLN
MATING CABLE PLUG: LEMO FGG.305.CYCC50Z

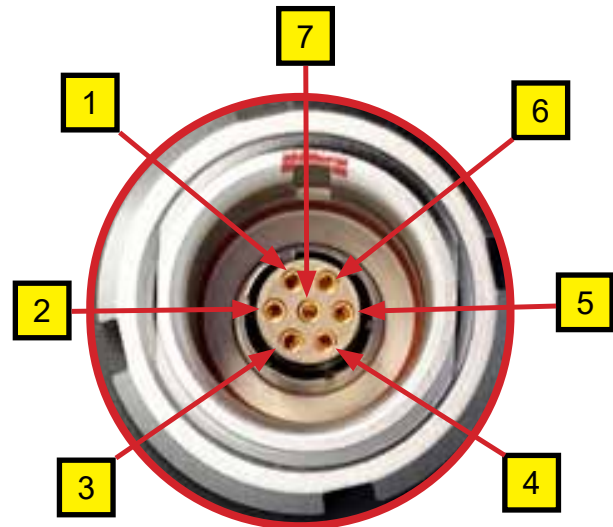

7 PIN K REMOTE CABLE CONNECTOR

REMOTE CONNECTOR: LEMO EGG.0K.307.CLN
MATING CABLE PLUG: LEMO FGG.0K.307.CYCC50Z

PIN #	5 PIN CONNECTOR (B OR K)	7 PIN K CONNECTOR
1	+5 VOLTS 100 mA MAXIMUM	+5 VOLTS 1 A MAXIMUM
2	REMOTE SWITCH (5 sec delay)	REMOTE SWITCH (5 sec delay) (+3V)
3	REMOTE SWITCH – NO DELAY	REMOTE SWITCH – NO DELAY (+3V)
4	X-RAY ON / FEEDBACK SIGNAL	X-RAY ON / FEEDBACK SIGNAL (+5V)
5	GROUND (COMMON 0 VOLTS)	RS232-RX
6		RS232-TX
7		GROUND (COMMON 0 VOLTS)

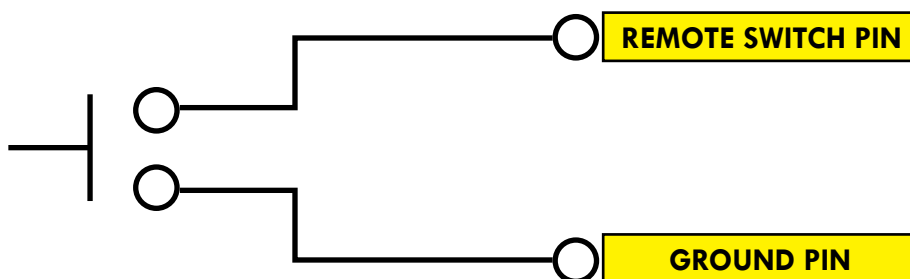

SERIAL INFORMATION
Baud Rate: 57600
8 – bit data
1 stop bit
Hardware flow control: None
Parity: none
Voltage Input: +/- 25V
Voltage Output: +/- 6V

Remote switch inputs are activated when connected to ground pin.

The block diagram below illustrates how the X-ray generator functions. The following sequence of events takes place each time the unit is fired:

1. User initiates operation of the machine.
2. The controller sends a signal to the converter to begin oscillating.
3. Once oscillating, the converter section changes the DC battery voltage to 22Khz AC.
4. The transformer charges the High Voltage Capacitor to about 9000 volts.
5. The spark gap arcs after the High Voltage Capacitor reaches peak voltage.
6. The pulse detector signals the control block that the unit has pulsed.
7. As the High Voltage Switch is closed, a high voltage transient of approximately 150,000 volts and 10-30 nanoseconds in duration is applied across the X-ray tube generating X-rays.

The closing of the High Voltage Switch produces an audible pulsing sound. The X-ray generator cannot produce X-rays without the pulsing sound so it serves as an additional warning the unit is functioning.

This unit generates X-rays through high voltage bombardment of a tungsten target.

The X-ray generator **does not contain radioactive materials**.

All the high voltage is contained within the aluminum canister and as long as the canister is not punctured the operator is not exposed to dangerous voltages.

BLOCK DIAGRAM

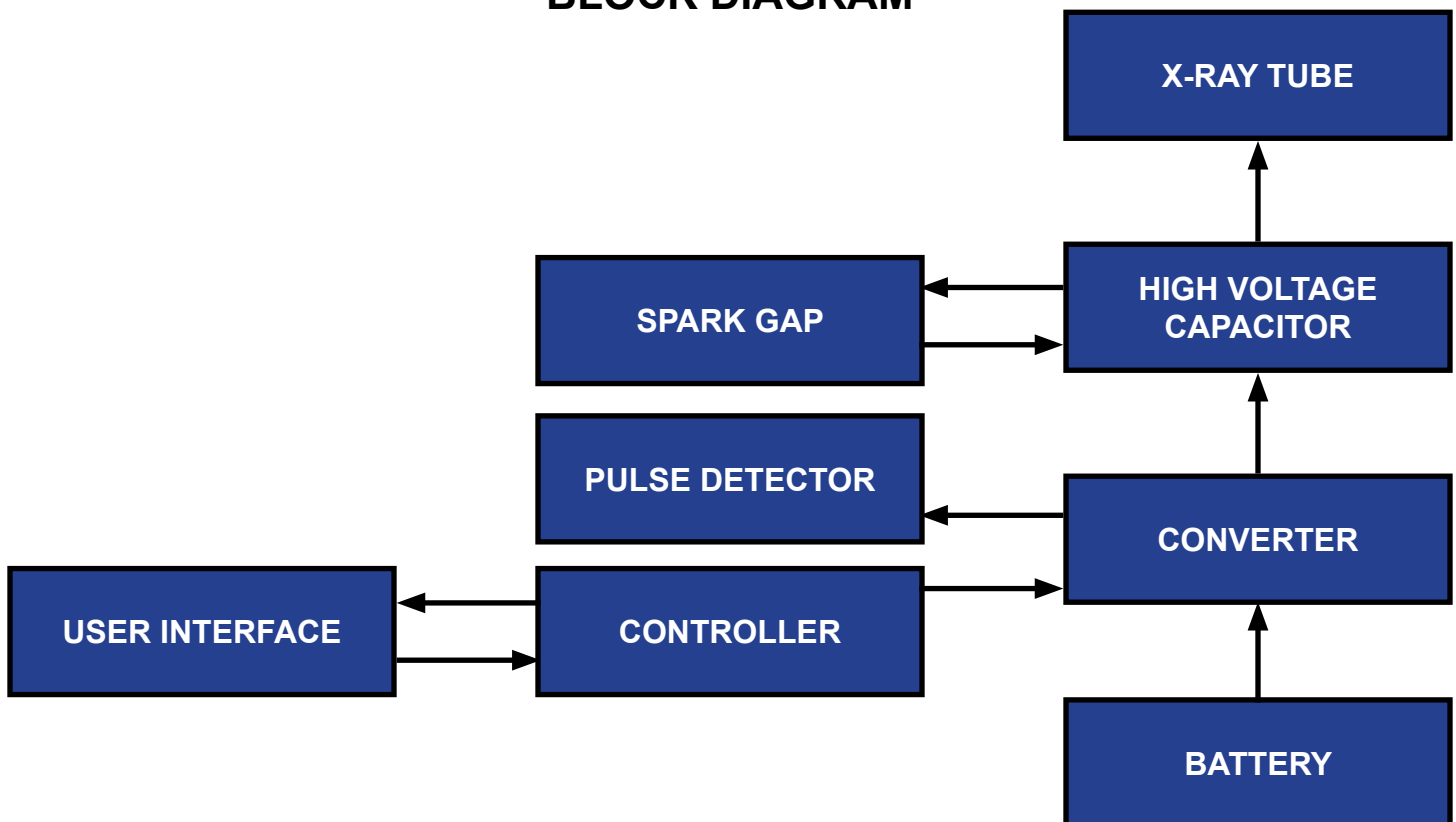

OPERATING INSTRUCTIONS

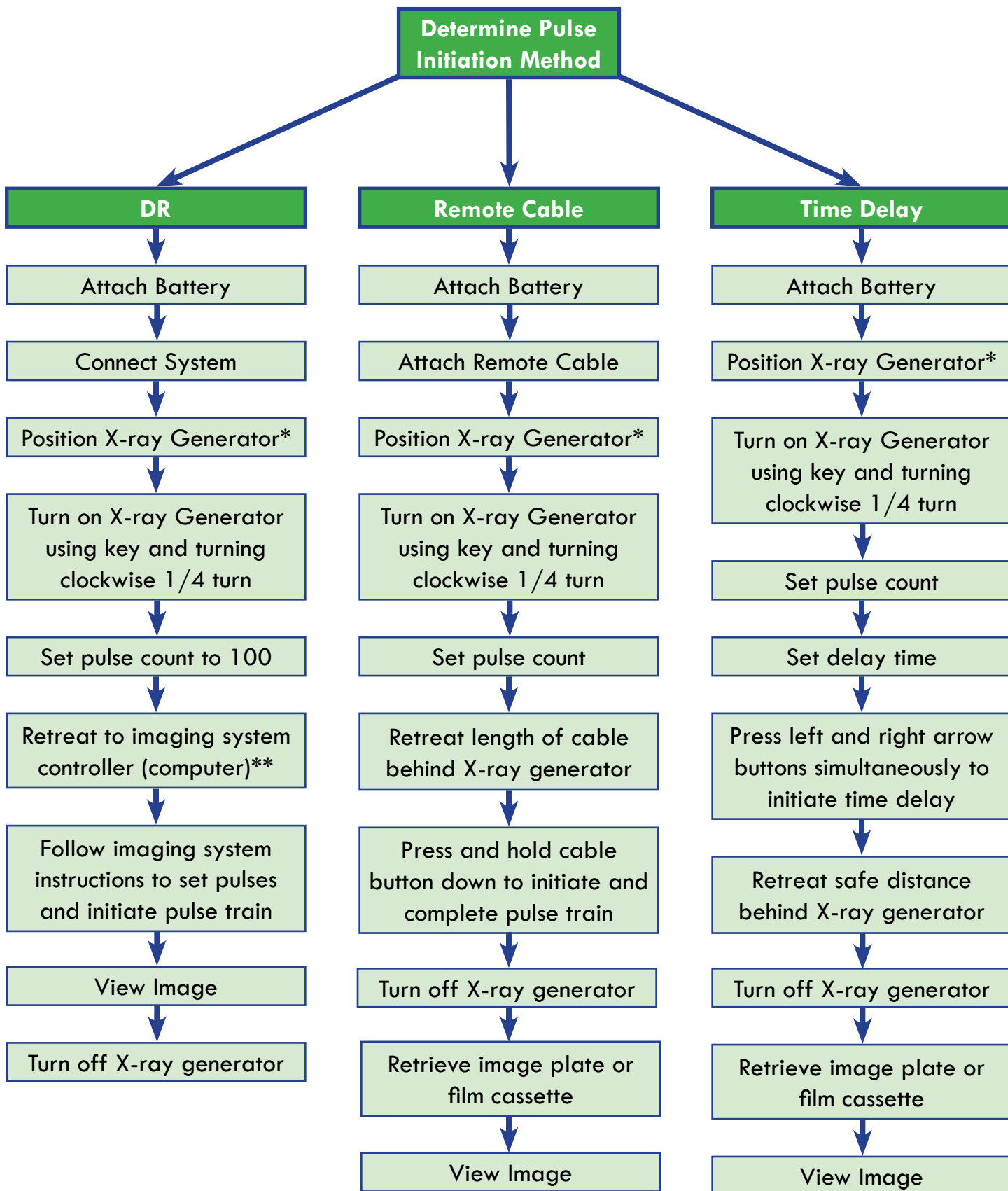

The following are basic operation instructions to take an X-ray image using the X-ray generator. Certain applications may require modifications to these basic procedures.

* The X-ray generator should be positioned directly in front of the object to be X-rayed and the imager placed directly behind the object to be X-rayed. Imager should be placed as close to the object as possible. Distance between X-ray generator and imager is usually 24 to 72 inches (60 to 180 cm). During operation the unit should be stabilized on a flat surface, a tripod, or a custom fixture suitable for holding the weight of the device. Refer to the Specifications table for details.

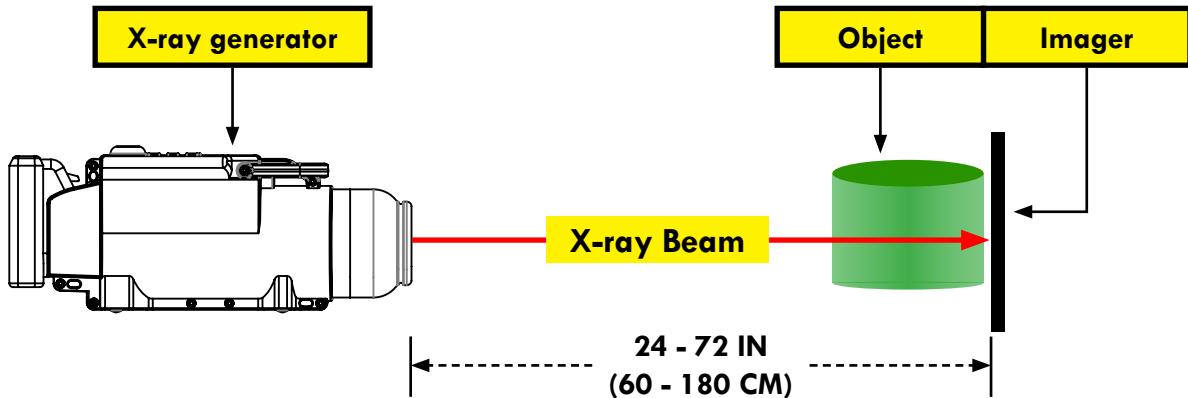

** The operator should always stand outside of the exclusion zone. The exclusion zone (below) should be a controlled area free of all personnel while X-ray pulses.

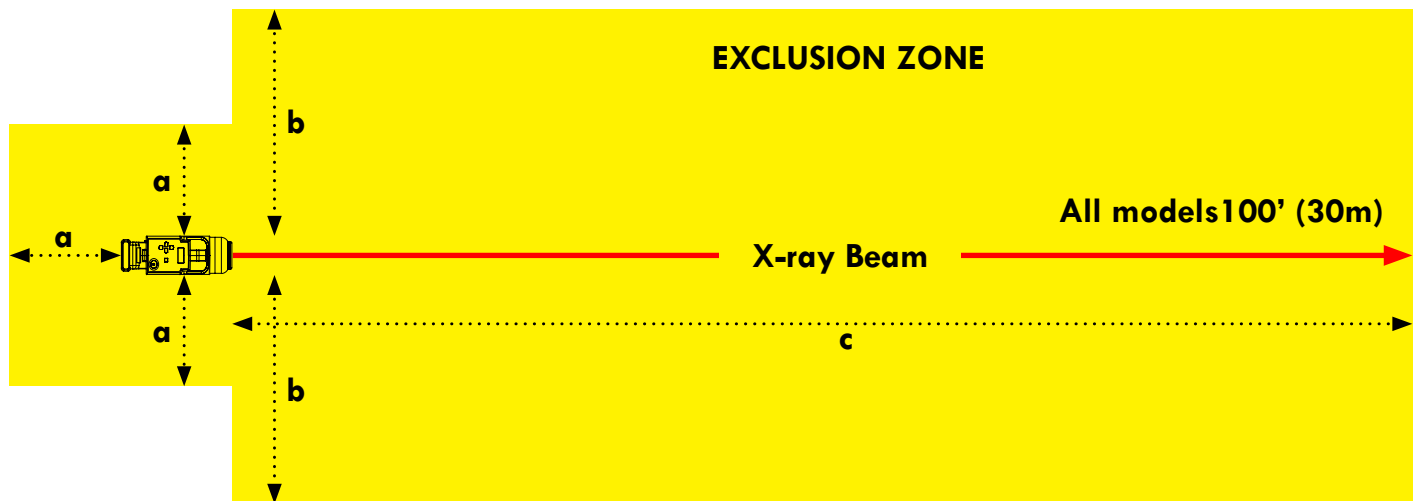

	XR150 12V
a	10' (3 m)
b	20' (6 m)
c	100' (30 m)

NAVIGATING THE MENU



- Home screen displays Counts (C) or Pulses (P) & Delay Time (D)
- Settings = Header (Title Screen) for the main menu
- Set CT = Set Counts (pulses)
- Set DT = Set Delay time (In delay mode only, safety time before initial pulse)
- Set PTR = Set Multiple Pulse Trains
- Home = Back to Home Screen
- ResetPC = Reset Pulse Counter
- Life PC = Lifetime Pulse Counter

BOOT SCREEN

The boot screen shows a "9" at the end of a normal boot cycle. If there is a problem during boot, make note of this number and tell the customer support representative when calling for help.

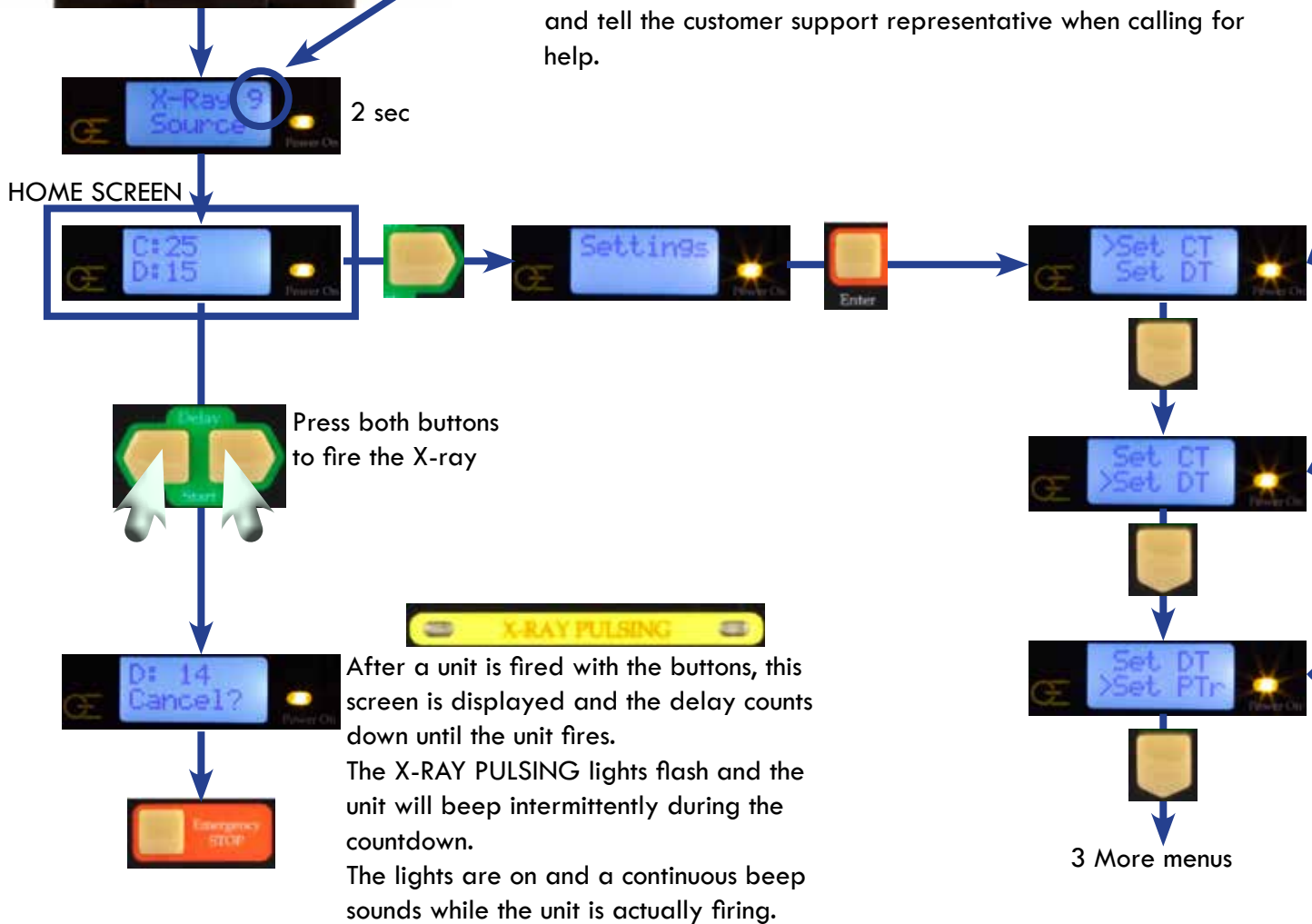

SET NUMBER OF COUNTS/PULSES



The number of counts (or pulses, depending on the Pulses per Count setting) that will be sent when the unit is fired.

Change this by selecting Set CT from the menu and press Enter.

Use arrows to adjust number of counts/pulses.

Right arrow from the right cursor position to select 'Save' and press Enter.

Left arrow from the left cursor position to cancel changes.



to change cursor position



SET DELAY TIME



Delay Time is the number of seconds between triggering the unit to fire with the buttons.

Change this by selecting Set DT from the menu and press Enter.

Use arrows to adjust the safety delay time (in seconds).

Right arrow from the right cursor position to select 'Save' and press Enter.

Left arrow from the left cursor position to cancel changes.

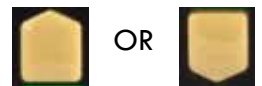

to change value



MANUALLY ENTERING PULSE TRAINS



FIRST set the number of counts/pulses (see above setting to 25)

Select Set PTR from the menu and press Enter.

Use arrows to adjust number of pulse trains and press the right arrow to set the time between.

Use arrows to adjust time between trains and press Enter.

Right arrow from the right cursor position to select 'Save' and press Enter.

Left arrow from the left cursor position to cancel changes.

Note: Press Enter and return to Home before pulsing the XR150. The XR150 will not pulse if software is not back to HOME screen.

The HOME screen will now look like this to indicate it is in pulse train mode

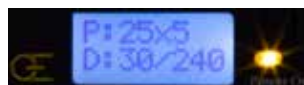

25 **Counts** per pulse train
x5 Pulse trains
125 **Counts** (375 pulses)

25 **Pulses** per pulse train
x5 Pulse trains
125 **Pulses**

DUTY CYCLE WARNING

The XR150 is a light duty machine that is not made to pulse continuously. The maximum duty cycle for the units is 100 counts (300 pulses) every four minutes. In temperatures above 90°F (32.22°C) or continual use situations, rest a minimum of 30 sec every 50 pulses and 4 min after every 200 pulses. Exceeding the duty cycle will shorten the life of the tube and head, and may also cause thermal damage to the circuit boards.

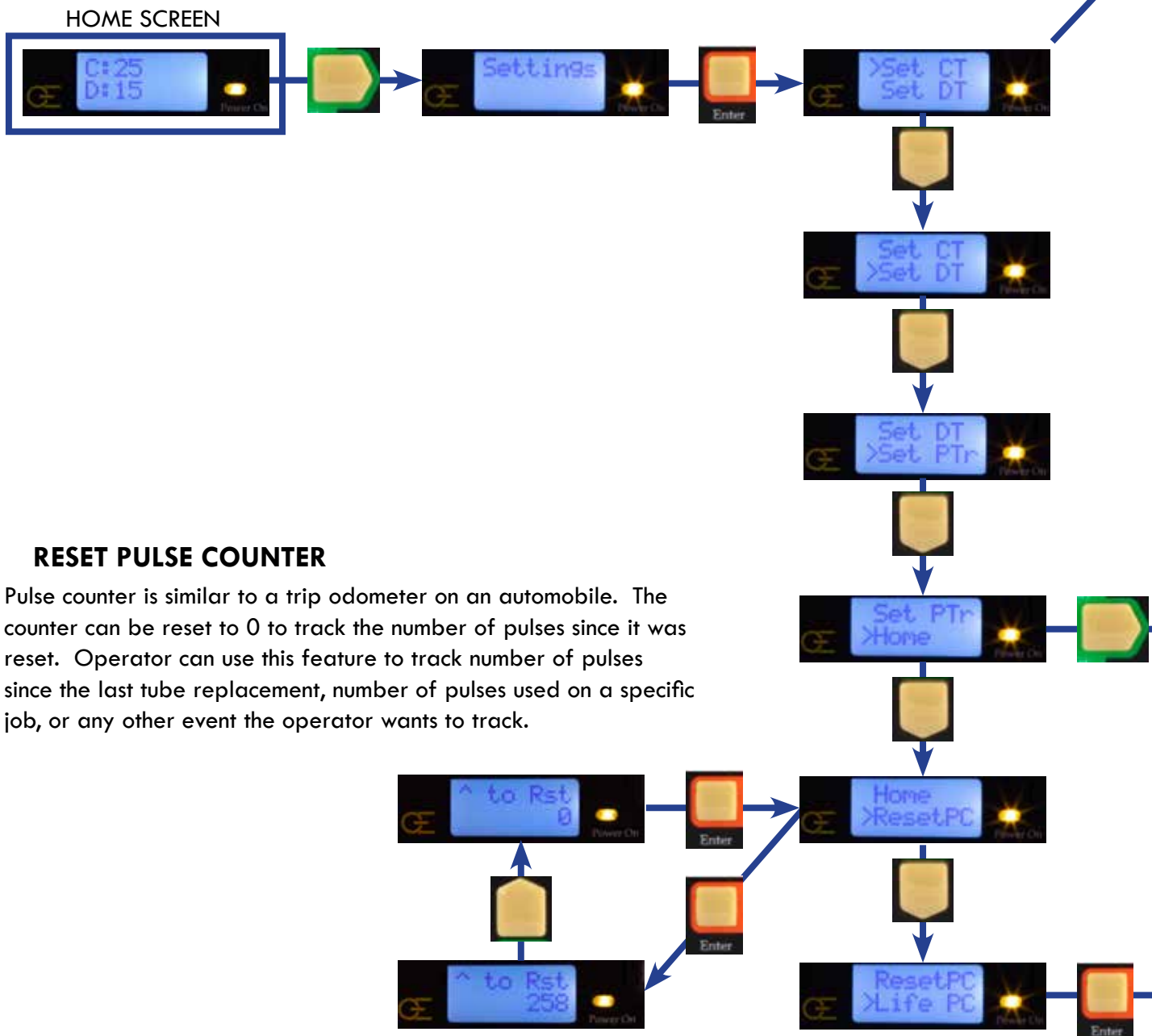

PULSE COUNT EXCEEDS DUTY CYCLE

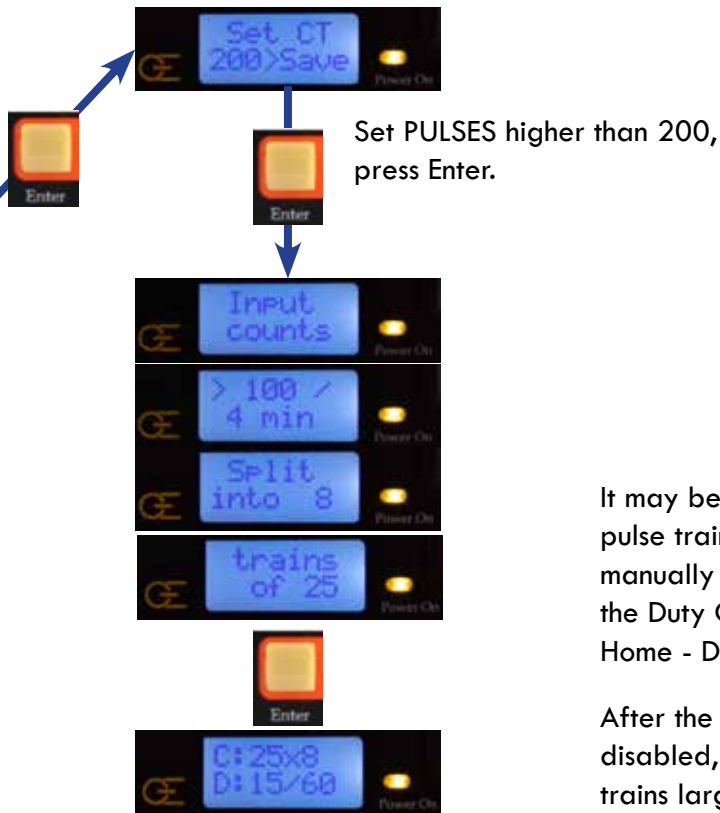

If the number of counts exceeds 100 (300 pulses), the unit will automatically split the pulses into consecutive pulse trains of 25 counts (75 pulses) with a delay 60-second delay between them. See the below example of setting 200 counts.

It may be necessary to fire the whole pulse train without splitting it. To manually override the split, **first** disable the Duty Cycle Warning in the Home - DutyWarn menu (see pg 17).

After the Duty Cycle Warning is disabled, the generator will allow pulse trains larger than 100.

Set the desired number of pulses on the Set CT screen and press Enter.

The unit is now ready to fire the complete entered pulse train.

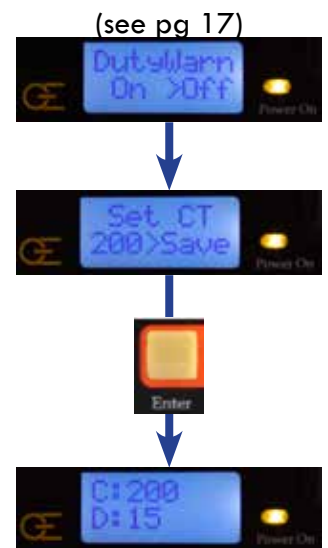

See the details of the Home menu on page 17.

LIFETIME PULSE COUNT

Lifetime pulse count tracks the total number of pulses the unit has fired. Please note the number displayed on the LCD is total number of PULSES the unit fired, NOT the total number of COUNTS. The XR150 fires three pulses for each count entered so the 12,549 Lifetime pulses that appear on LCD below equals 4183 lifetime COUNTS the XR150 has fired.





Use Arrows to change setting
Press Enter to select

BACKLIGHT

Allows the user to turn the backlight on and off.



PULSES PER COUNT

Allows the user to switch between 1 or 3 pulses per count.



DISABLE DUTY CYCLE WARNING

Allows the user to turn off the duty cycle warning in order to send longer pulse trains without automatically splitting them.



GENERATOR IDENTIFICATION

Displays the software version, generator serial number, and high voltage head number.

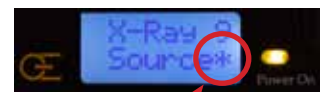

ASTERISK (*) APPEARS ON BOOT SCREEN WHEN WARRANTY HAS BEEN VOIDED

MULTIPLE PULSE TRAIN EXCEEDS DUTY CYCLE

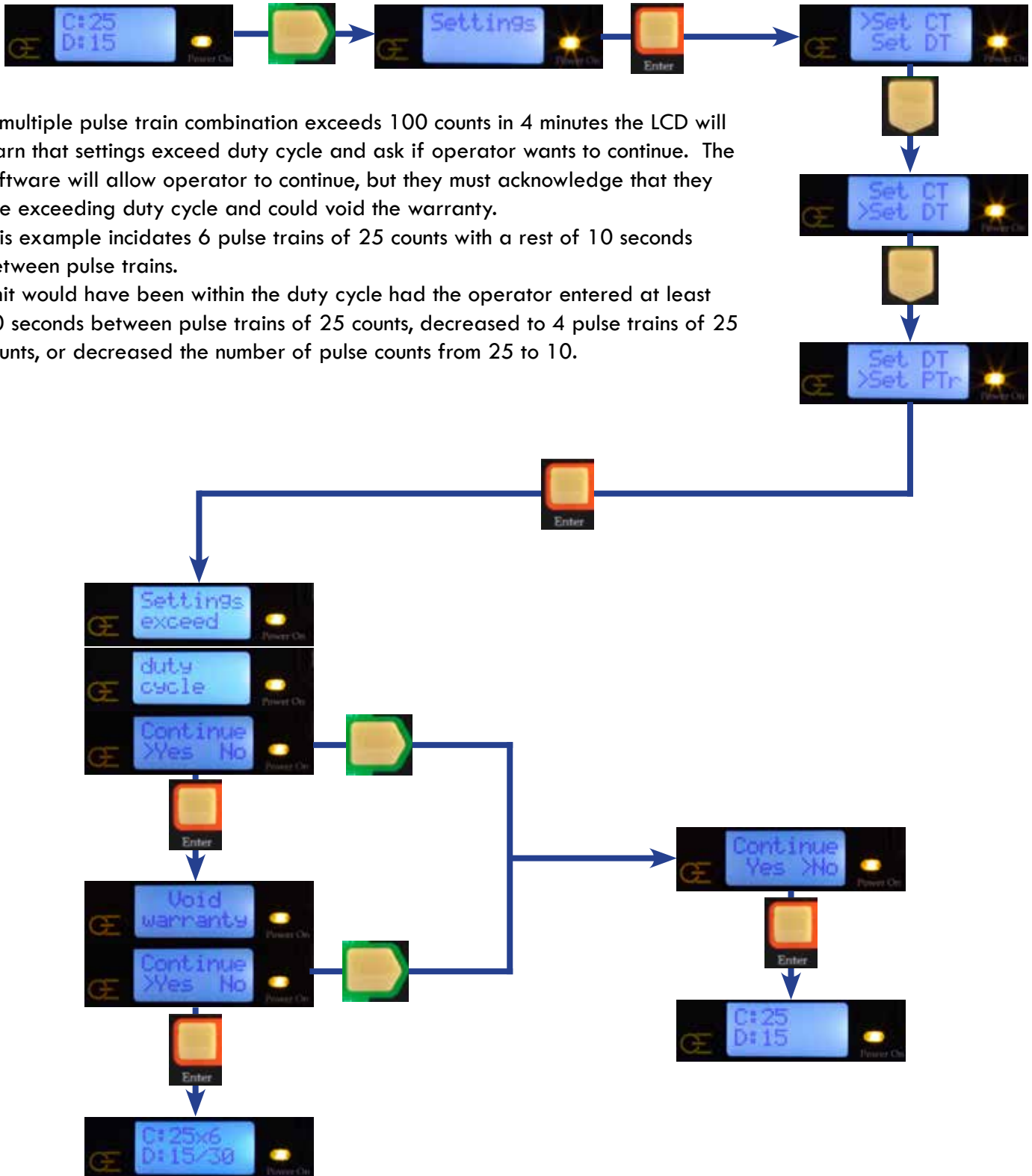

If multiple pulse train combination exceeds 100 counts in 4 minutes the LCD will warn that settings exceed duty cycle and ask if operator wants to continue. The software will allow operator to continue, but they must acknowledge that they are exceeding duty cycle and could void the warranty.

This example indicates 6 pulse trains of 25 counts with a rest of 10 seconds between pulse trains.

Unit would have been within the duty cycle had the operator entered at least 60 seconds between pulse trains of 25 counts, decreased to 4 pulse trains of 25 counts, or decreased the number of pulse counts from 25 to 10.

ERROR MESSAGES



Battery voltage is too low to pulse XR150. Charge the battery.



Pulse rate is slower than 1 pulse per second. Either low battery, problem with transformer, or electronics. Charge battery, or replace oscillator board.

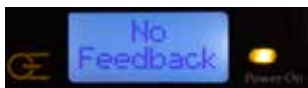

Current not detected. No current flow going to the head. Occurs at beginning of pulse train. Check 20 amp fuse on the oscillator board. If fuse is ok problem could be in head or electronics. Replace board or send back for repair.



Displayed if duty cycle is reached (100 counts in 4 minutes).



The failsafe warning LED is not lighting up. The control board may need to be replaced or the unit may need to be returned for service.

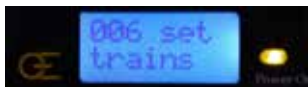

Occurs when the generator is powered off with multiple pulse trains set. On the Continue screen, select NO to return to a single pulse train, or YES to keep the multiple train setting.



The boot screen displays an asterisk (*) when the warranty has been voided.



The boot screen shows a "9" at the end of a normal boot cycle. If there is a problem during boot, make note of this number when calling for help.

SYMPTOM	TEST	ACTION
Unit makes loud popping noise while pulsing.		Stop and return unit for repair. Continued use in this condition will cause additional damage to the unit.
Oil leaking from unit.		Return for repair.
No “power on” light	Check battery voltage Check battery connection	Replace or charge battery Ensure battery is securely attached and battery clips are not bent or broken.
Power on lights, but X-ray does not pulse.	Check the battery voltage. Check the 2amp fuse.	Charge or replace the battery. Replace the fuse if necessary.
Power on lights, X-ray pulsing light does not illuminate, X-ray does not pulse	Check the battery voltage.	Go to settings menu failsafe disable To fix light replace processor board
Low Battery Please Charge	Appears if battery is below 15V	Charge the battery
X-ray pulses, but no image or black image.	Test X-ray output.	Return unit for tube replacement if no X-ray output dose.
Unit stops pulsing in the middle of a pulse train and LCD displays 00.	Check the battery voltage. Check 20 amp fuse.	Charge battery if necessary. Replace the fuse if blown.

RECOMMENDED PULSE SETTINGS

The chart below lists **approximate** pulses necessary to penetrate various materials. **Settings vary depending on imaging system used.** Refer to imaging system instructions for more information.

MATERIAL	COUNT (PULSE) SETTING
	XR150 12V
Cardboard, light wood, plastic	10 counts (30 pulses)
Light metal	20 counts (60 pulses)
Steel 1/4" (6 mm)	50 counts (150 pulses)
Steel 1/2" (13 mm)	90 counts (270 pulses)

If the radiograph is too dark, the film is **underexposed**.

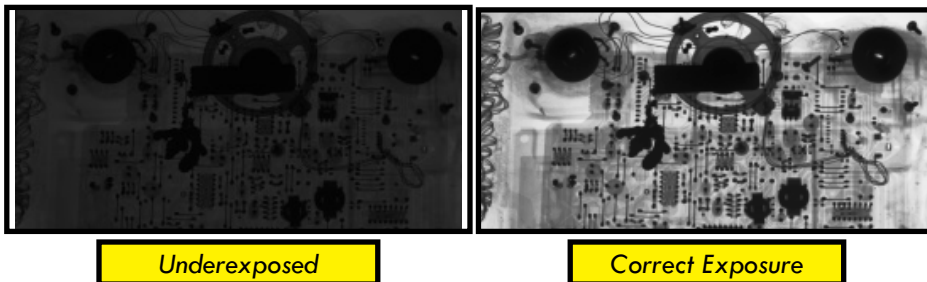

Underexposure can be corrected by increasing the number of pulses and/or decreasing the distance between the imaging medium and the X-ray generator.

If the radiograph is too light the film is **overexposed**.

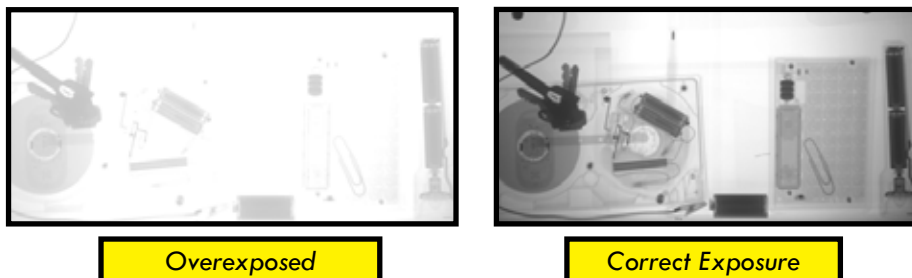

Overexposure can be corrected by reducing the number of pulses and/or increasing the distance between the imaging medium and X-ray generator.

EC DECLARATION OF CONFORMITY

This declaration of conformity is issued under the sole responsibility of the manufacturer

MANUFACTURER

Company name: Golden Engineering, Inc.
 Full address: PO Box 185
 6304 Means Rd.
 47330
 Place: Centerville, IN
 Country: USA

EUROPEAN AUTHORISED REPRESENTATIVE

Which is established in the European Union and has access to the Technical File

Company name: Certification Experts
 Full address: Nieuwstad 100
 Postal code: 1381 CE
 Place: Weesp
 Country: The Netherlands

DESCRIPTION AND IDENTIFICATION OF THE MACHINERY

Generic name: XR150 X-ray Generator
 Function: Radiography inanimate objects by producing x-ray pulses of short duration.
 Model: XR150
 Serial number range: 3400 - 10.000
 Commercial name: XR150 X-ray Generator

COMPLIANCE

The manufacturer declares that the above mentioned machinery fulfills all relevant provisions of

Machinery Directive 2006/42/EC Low Voltage Directive 2014/35/EU
 EMC Directive 2014/30/EU

In conjunction with the following harmonised standards and where appropriate other technical standards and specifications for the risk assessment

EN-ISO 12100:2010
 for the design and manufacture

IEC 61234-1:2012, IEC 61000-4-2:2008, IEC 61000-4-3:2006/A1:2007, IEC 61000-4-4:2004/A1:2010, IEC 61000-4-6:2008, EN 50518:2012

Place: Centerville, IN Name: Roger Golden
 United States of America Function: President

Date: November 29, 2016 Signature: 

SPECIFICATIONS

PHYSICAL DIMENSIONS INCLUDING BATTERY PACK	
MODEL	XR150
LENGTH	10.62 in (26.97 cm)
WIDTH	3.03 in (7.70 cm)
HEIGHT	4.07 in (10.03 cm)
WEIGHT	5.3 lb (2.4 kg)
X-RAY OUTPUT	
X-ray dose per pulse (12 inches in front of unit)	2.5 to 5.0 mR per count (0.83 to 1.67 per pulse)
Pulses per battery charge	2000 counts (6000 pulses)
Pulses per second	4 counts (12 pulses)
Expected tube life (glass tube)	30,000 counts (90,000 pulses)
X-ray source size	1/8 in (3 mm)
Maximum Photon Energy	150 kVp
X-ray pulse width	10 nanoseconds per pulse
ELECTRICAL AND THERMAL CHARACTERISTICS	
Battery voltage	12 V or 10.8 V
Battery type	Li Ion
Battery recharge time	1 Hour
Current draw	9A @12V
Average X-ray Tube Current	0.1 mA
Storage Temperature	0° to 120° F (-18 to 50° C)
Operating Temperature	0° to 120° F (-18 to 50° C)
Maximum duty cycle	100 counts (300 pulses) every 4 min (1500 counts or 4500 pulses per hour)
High Temperature or High Use Duty Cycle	Rest 30 sec every 50 pulses and 4 min every 200 pulses
IP Rating	IP 54
Minimum Standby Time	10 hours
Warm-up	None required

ITEM	PART NUMBER
Thumbwheel Key	2002000
Flat key	5951020
DeWalt® Battery 12V Li-ION (3 Ah)	1800105
DeWalt® Battery Charger (110V) DCB115	1800151
DeWalt® Battery Charger (220V) DW 220	1800164
5-Pin K Remote Cable	1809022
5-Pin B Remote Cable	1809013
7-Pin K Remote Cable	1809030
ADAPTER CABLE (5 PIN K PLUG / 5 PIN B RECEPTACLE)	1809023
ADAPTER CABLE (5 PIN K PLUG / 4 PIN B RECEPTACLE)	1809024
ADAPTER CABLE (5 PIN K PLUG / 7 PIN K RECEPTACLE)	1809033
ADAPTER CABLE (7 PIN K PLUG / 5 PIN B RECEPTACLE)	1809031
ADAPTER CABLE (7 PIN K PLUG / 5 PIN K RECEPTACLE)	1809032
ADAPTER CABLE (7 PIN K PLUG / 4 PIN B RECEPTACLE)	1809034
Tripod Mount	1800056
Tripod Kit (includes Tripod Mount and Legs)	1803041
Carrying case (holds X-ray, 2 batteries, charger, cable)	1708025
Handle	4000150
10 MIL SNAP ON COPPER FILTER	1800210
30 MIL SNAP ON COPPER FILTER	1800230
40 MIL SNAP ON COPPER FILTER	1800240
60 MIL SNAP ON COPPER FILTER	1800260
LEAD COLLIMATOR CAP SOLID	1800265
LEAD COLLIMATOR CAP 20 degree	1800251
LEAD COLLIMATOR CAP 30 degree	1800252
LEAD COLLIMATOR CAP Rectangle	1800253

Golden Engineering, Inc. warrants XR150-12V X-ray units made and sold by it or its authorized representatives to be free of **defects in materials and workmanship** for a period of twelve (12) months from the date of shipment to the end user. **Warranty does not cover maintenance required due to life.** To make a claim under this limited warranty, customer must ship the entire unit (or the component believed to be defective) to Golden Engineering, post-paid. Golden Engineering, Inc. assumes no liability for units or components shipped until they are actually in the custody of Golden Engineering, Inc. Provided Golden Engineering, Inc. in its sole discretion, is satisfied that the failure is not the result of excessive use, abuse, misuse, accident, modification or improper disassembly or repair, Golden Engineering will provide parts and labor required to repair the unit. Golden Engineering reserves the right to use reconditioned and remanufactured components that meet original specifications. The unit or component will be returned and shipped to customer at customer’s expense. THIS EXPRESS LIMITED WARRANTY IS IN LIEU OF ALL OTHER WARRANTIES AND GUARANTEES, EITHER EXPRESS OR IMPLIED OR CREATED BY OPERATION OF LAW.

INSTRUCTIONS FOR TRANSPORTATION, STORAGE, AND DISPOSAL

The X-ray generator is shipped in a rigid case or strong fiberboard box with custom foam insert. When transporting, remove the battery pack and transport in a rigid case or fiberboard box with sufficient cushioning. Store the X-ray generator in a dry environment within temperature ranges within in the specifications. For disposal remove the tube and follow all applicable environmental laws. Alternatively, the X-ray generator may be returned to Golden Engineering for proper disposal.

RETURNING UNIT FOR REPAIR

Complete the repair form at www.goldenengineering.com/technical.html and include a copy of the printed form with the repair. If you do not have internet access prior to sending repair then include a letter containing a brief description of the problem, contact name, phone number, and return address.

- Remove battery before shipping the unit.
- Accessories are not necessary with units shipped back for repair.
- Be sure the unit is securely packaged for shipment and seal in plastic bag if there is an oil leak.

<p>Manufactured by: GOLDEN ENGINEERING, INC. 6364 Means Road, Box 185 CENTERVILLE, IN 47330 USA Phone: 1-765/855-3493 Fax: 1-765/855-3492 Web: www.goldenengineering.com Email: service@goldenengineering.com</p>
<p>European Representative: Certification Experts Europe Nieuwstad 100 1381 CE Weesp, The Netherlands</p>

Country of Origin	USA
Model	XR150 12V
Serial Number	
Delivery Date	

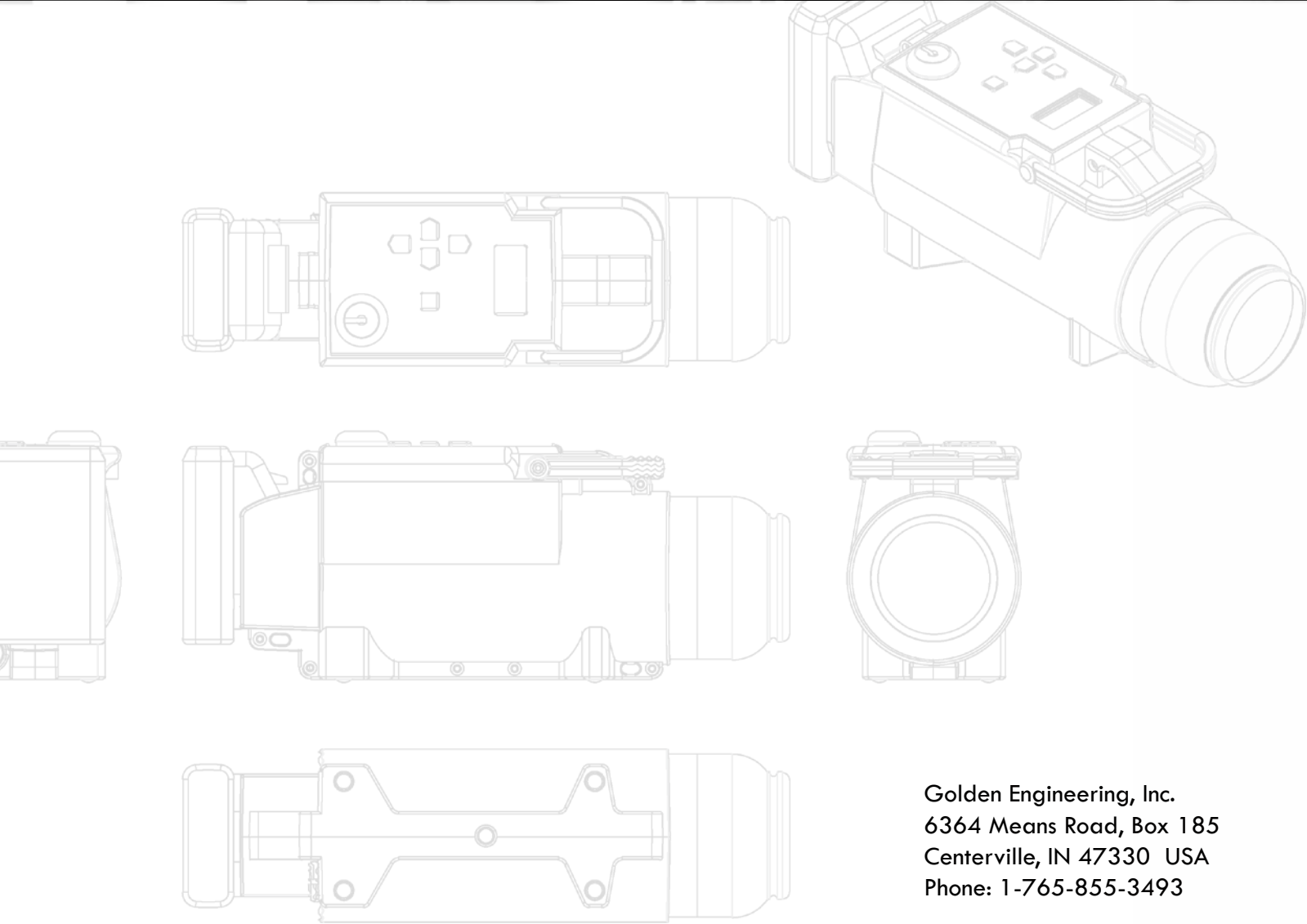

Golden Engineering, Inc.
6364 Means Road, Box 185
Centerville, IN 47330 USA
Phone: 1-765-855-3493